

**Product – AFD425 with Direct H Motor Drive**

Details as follows:

- This based upon the same basic drive unit (BDU) as the AFDE400/410
- To enable a pneumatic drive a motor mounting adaptor is assembled in place of the electric pulley housing – as below

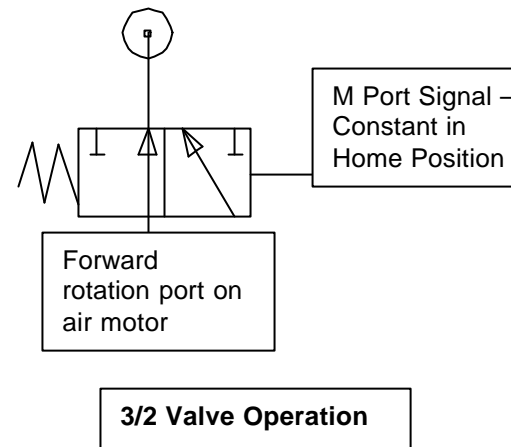
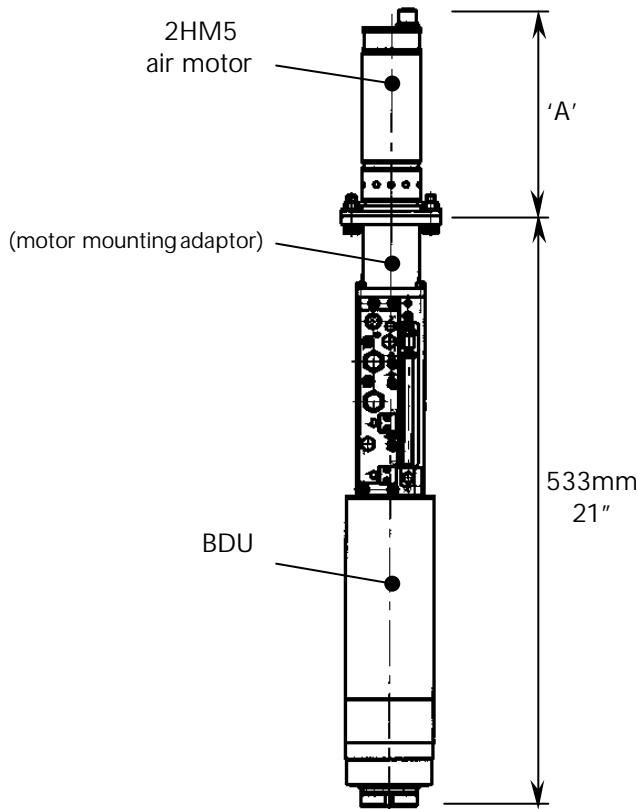

**Lou Zampini & Associates**  
 2 Douglas Pike, Rt. 7  
 Smithfield, RI 02917  
 1 800 353 4676  
 FAX 1 401 679 0165

A 3/2 Valve (supplied) is required with an A1 block in order to turn the air motor off at the home position. Similarly external valves(not supplied) will be required with the A6 block.

	Speed rpm	Length 'A' (mm)
2HM5-3300	3300	143.5
2HM5-2100	2100	143.5
2HM5-950	950	187
2HM5-550	550	187
2HM5-350	350	187

	Speed rpm	Length 'A' (mm)
2HM5-150	150	224.5
2HM5-100	100	224.5
2HM5-40	40	224.5

AFD425 with direct H motor drive



Medium duty unit

- Multiple spindle head options for drilling and tapping – same as 400 series
- Modular design
- Full feature control block (simple control block optional)
- Automatic cycle with external Valve (not supplied) to stop air motor
- Adjustable depth control
- Quill sealed to IP64

Type

Pneumatic Feed and Drive Drill / Tapper

Specification

CAPACITY IN MILD STEEL

Drilling (HSS Jobber Drill) 10 mm/ 3/8"

Tapping (Spiral Flute Bright Tap) M6/ ¼-20

POWER 0.85 HP

THRUST 160lbs @ 90psi with spring return

180lbs @ 90psi with spring removed

SPEEDS 40-3300 rpm through different air motors – see 2HM5 range

NOISE LEVEL TBA

AIR CONSUMPTION 35cfm (continuous running)

STROKE 4"

WEIGHT TBA

Options – As existing AFD415/AFDE400/410

Control Options including;

- Dwell
- Peck feed
- Skip Drilling
- Hydraulic feed control
- Electric/Pneumatic interfaces

Multiple Spindle Heads

- Mounting clamps
- Push-pull tapping
- Output spindles
- Silencer