

AFD425 Tension Tapper – Air Feed/Air Motor Drive



Cyl



HCU for Rapid
Advance

Tension/Compression Quick
Change Floating Tap Holder

Motor Reversal Circuit

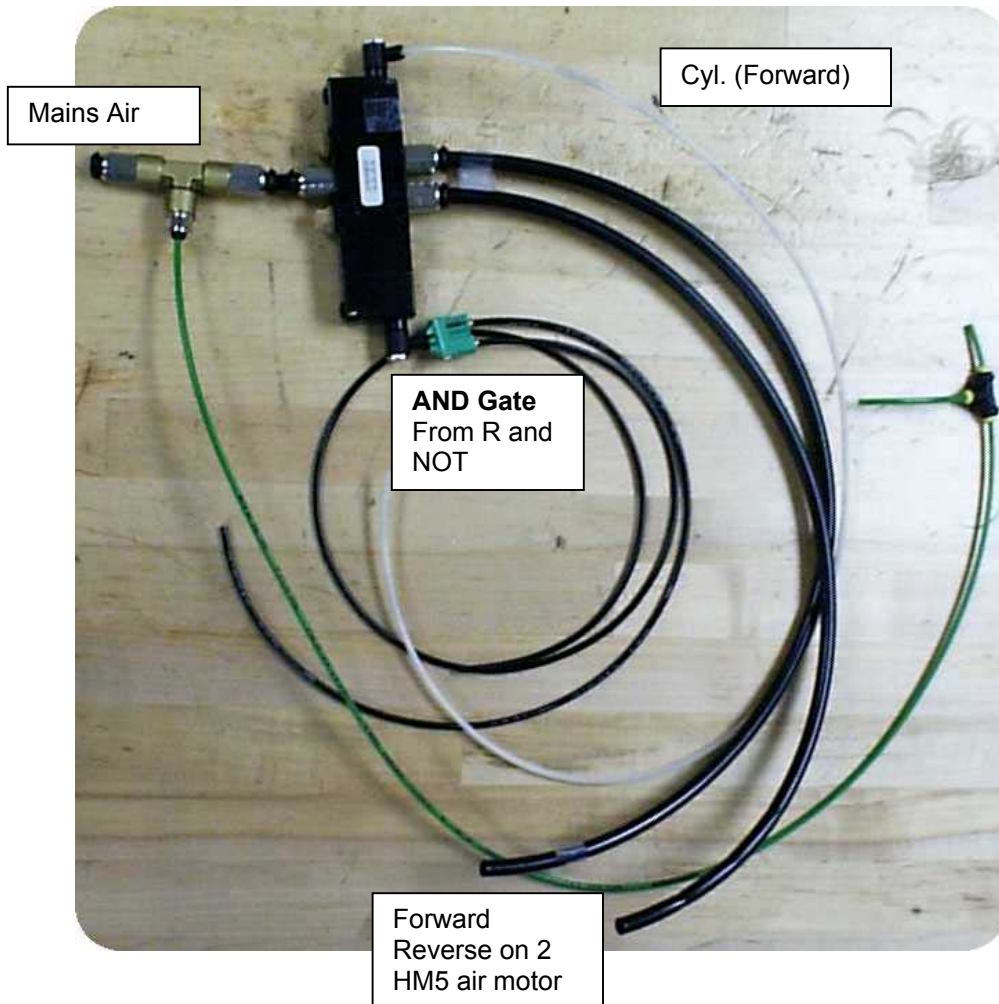
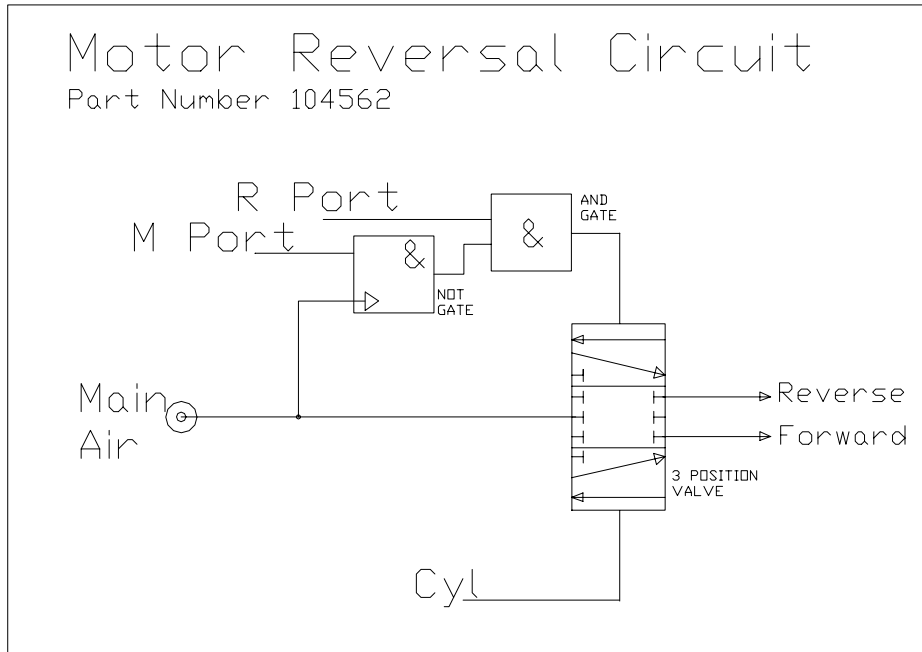

Not Gate
1 M Port
2 Mains Air
3 Output to And Gate



All Pneumatic “Tension” tapping uses an AFD unit with external air motor drive (AFD425 or AFD625) to allow the spindle direction to be reversed. The tap is held in an axially floating holder to allow it to cut its own thread. The axial float must always have tension, compression is optional depending on the application.

How it works

The unit is advanced through air pulse into 1 port or electrical pulse into S1 Solenoid Valve. There is a pressure tapping that starts the motor in the forward direction (see circuit diagram 104562)

An HCU is set to give the required rapid advance controlling the feed on the tap just as it enters the pre-drilled hole.

The tap holder with axial float will allow the tap to feed through at the rate required.
(Note can be used with multiple spindle heads provided each spindle has axial float.)

At end of stroke (adjustable from 0 – 4”) the depth signal reverses the motor direction using circuit (104562), tool also automatically retracts.

When unit returns to home position the air motor stops ready for the next tapping cycle.

External control is through the A1 Control Block.

Tension/Compression Spindle Float on AFDE400/410/420/610/620

Features

Provides both radial float and tension and compression lead compensation.

Quick Change of Taps – 51 series tap adaptors ordered separately

Low friction ball bearing drive

Tension and compression strokes can be varied to suit the application

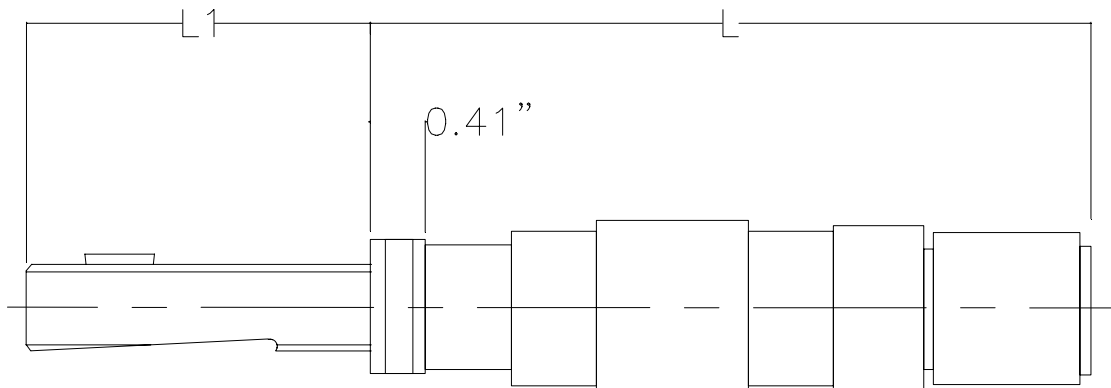

Part Number	Max Dia	T.I.R. Float	Total Stroke	L	L1
321-1-210FC	1.38	0.070	0.59	4.85	2.59
321-1-210FT			0.59	4.26	2.59
321-1-210TNC			0.59	*	2.59
321-5-210-FC	1.38	0.070	1.58	6.82	2.59
321-5-210FT			1.58	5.24	2.59
321-5-210TNC			1.58	*	2.59

FC = Full Compression, FT = Full Tension,

TNC = Tension and Compression standard is 50% of each unless specified

* Will vary according to amount of tension and compression – subtract tension stroke from L

Quick Change Tap Adaptors – 51 series

Quick-Change Tap Adaptors Permit
5-Second Change Of Taps

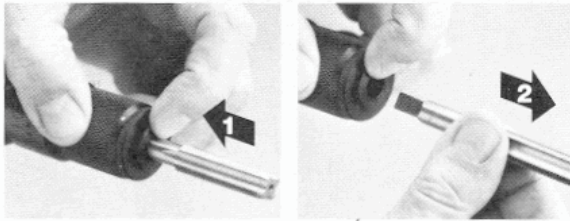

Quick-Change Tap Holders Permit
5-Second Change Of Tap Adaptors

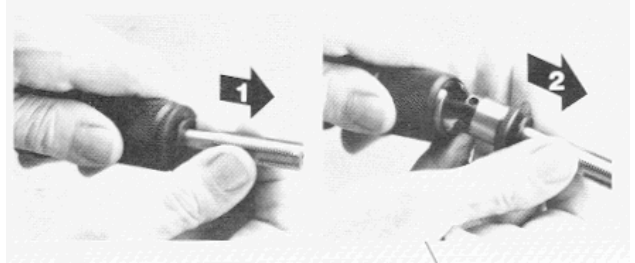

51 Series Tap Adaptors

Item Number	Tap Size	L1	L2	L3	L4	D1	D2	Max Dia	Projection		
51-106	0 – 6	0.84	0.31	0.16	0.37	0.73	0.748	1.18	1.51		
51-108	8										1.57
51-110	10		0.39							1.73	
51-112	12		0.31							1.79	
51-004	1/4		0.39		0.38					1.80	
51-005	5/16									1.95	
51-006	3/8									2.11	
51-007	7/16									2.36	
51-008	1/2									2.55	
51-009	9/16		0.31						2.79		

NTER-CC Extended Range, Close Centre Tap Adaptor

Permits the use of larger taps with small diameter holders
NOT RECOMMENDED for high torque applications

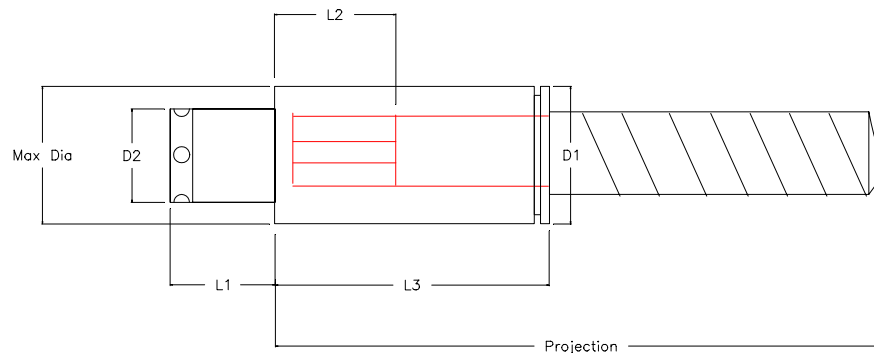

Part Number	Tap Size	L1	L2	L3	D1	D2	Max Dia	Projection
51-010	5/8	0.83	0.99	2.19	1.17	0.748	1.18	4.24
51-011	11/16							4.39
51-012	3/4							4.55
51-013	13/16							4.77
51-014	7/8							4.93

Full Feature Control Block A1 - Forward Feed Air Only, Return Feed Air/Spring or Both

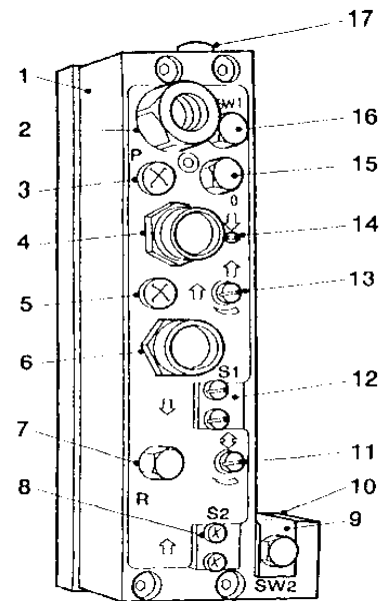

Summary of Ports/Features

- 2 Mains Air Inlet 1/4" BSP adaptor supplied to 1/4" NPT
- 3 P Port tapped M5/10-32, signal port for Pecking/Dwelling
- 4 Manual Retract Button - Red
- 5 1 Port tapped M5/10-32, for remote start air pulse signal
- 6 Manual Start Button - Green
- 7 R Port tapped 1/8" BSP with adaptor to 1/8" NPT supplied supply for air return
- 8 S2 Electric Interface Port, for remote retract using a solenoid valve (24Vdc/110VAC)
- 9 SW2 Electric Interface Port, for electric depth signal through a proximity switch (M8)
- 10 End Stop - to automatically return tool when at depth
- 11 Main Air Regulating Screw
- 12 S1 Electric Interface Port, for remote start using a solenoid valve (24Vdc/110VAC)
- 13 Retract Rate Regulating Screw
- 14 Advance Rate Regulating Screw - **functions on Air Return tools Only**
- 15 O Port tapped 1/8" BSP with adaptor to 1/8" NPT supplied, remote depth/retract, signal port for Pecking/Dwelling
- 16 SW1 Electric Interface Port, for electric datum signal through a proximity switch (M8)
- 17 M Port tapped M5/10-32, for air signal in datum position - constant

Input and Output Signals - NOTE : Remote Electrical Signals Require an Interface Kit

Input Signal	Output Signal	Manual	Remote Air	Remote Electrical (Requires additional kit)	Automatic
	Datum		M Port (17) Constant Air Signal	SW1 (16) Constant Signal Through M5/8 Proximity Switch	
Forward		ST Green Button (4)	1 Port (5) Give Pulse Air Signal	S1 (12) Through Solenoid Valve - Pulse Signal	
	Depth		O Port (15) P Port (3) Constant At Depth	SW2 (9) Constant Signal Through M5/8 Proximity Switch	
Retract		SP Red Button (6)	O Port (15) P Port (3) Give Pulse Air Signal	S2 (8) Through Solenoid Valve - Pulse Signal	End Stop (10)

NOTE: - Main Air Inlet (⊙)

The main air inlet ⊙ (1/4" BSP or NPT) must be connected to an air supply for both the AFD and AFDE tools as the air supply to the tool and block is provided through this port.

Circuit Diagram

The circuit diagram below shows the workings of the control block circuit.

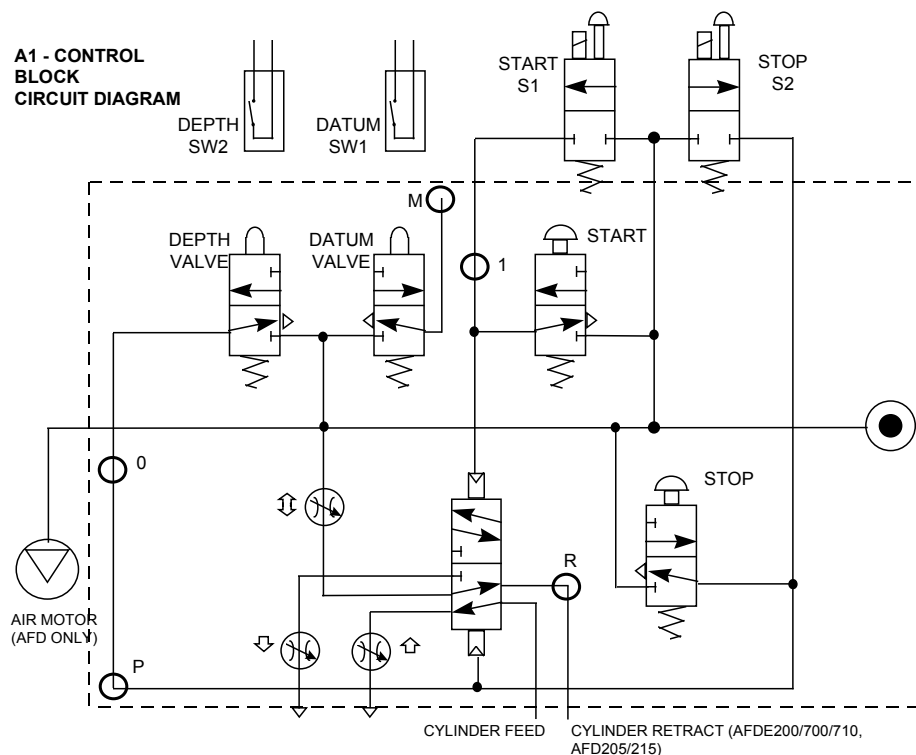

Flow Control Settings

Tool Type	13 ↑ Step 1	11 ↑↓ Step 2	14 ↓ Step 3
AFD426/625	Affects Retract Rate Only	Affects Forward Rate Only	No Affect

Electrical Interface Kits

The interface kits are used to control the AFD range using electrical signals to provide start and retract signals and feedback for depth and datum. Generally for use with P.L.C. s (Programmable Logic Controllers) the kits contain solenoid valves and proximity switches of differing types depending on the method of control and on which control block they are being used with. All solenoid valves and proximity switches are of the plug in type.

Supply voltages are 10-30V DC for the proximity switches and commonly 24V DC for the solenoid valve. The proximity switches are supplied in both PNP (most common - sourcing) and NPN (sinking) and are normally open (NO).

The solenoid valves have DIN type connections on the plug and can be normally open (NO) or normally closed (NC - most common).

Fitting an Interface Kit to an A1 Control Block

Remove the blanking plates at positions S1 and S2. Fit the 2 solenoid valves ensuring the gasket is fitted correctly between the valve and the control block.

To fit the proximity switches remove the blanking plugs at positions SW1 and SW2.

NOTE: There is a constant air supply from the SW1 port. The proximity switch must seal against this air pressure. There is an air supply from the SW2 port at depth only and again the proximity switch must seal against this air pressure.

With the tool at the datum position fit a proximity switch in SW1 by gently rotating clockwise until a some resistance is felt. Rotate the switch approximately one turn anti-clockwise and make sure the switch is sensing. Similarly with the depth stop depressed insert the other switch in SW2 and follow the same procedure. Make sure the switch is sensing.

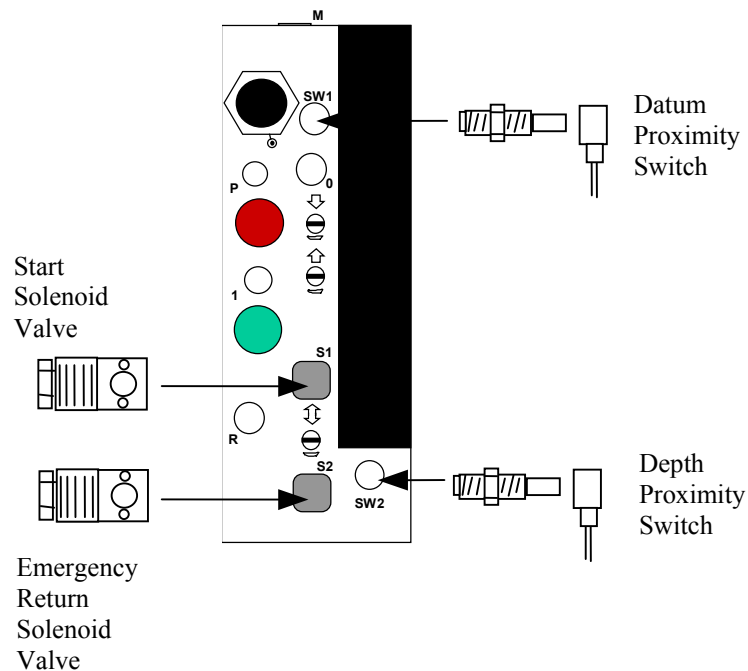

Operation of Interface Kits

Input Signals:

Start - For interface kits C10 and C12 - To start the cycle energize the Normally Closed solenoid at position S1 for approximately 0.5 seconds. The tool will cycle automatically.

For kit C11 - The Normally Open solenoid valve is fitted to S2 and so to start cycle energize both solenoids (Note with electric power off and air on air will exhaust around red stop button)

NOTE: External solenoid valve can also be used to give pulse start signal to 1 port.

Emergency Return - For interface kits C10 and C12 - To stop the cycle and return to home energize the Normally Closed solenoid at position S2. For approximately 0.5 seconds. The tool will return to datum.
 For kits C11 - The Normally Open solenoid valve fitted to S2 is de-energized to stop the cycle. This also acts as a fail safe should the electrical power fail.

NOTE: External solenoid valve can also be used to give pulse start signal to P or O port.

Output Signals:

Depth - The proximity switch at SW2 will provide a signal upon reaching depth.

Datum - The proximity switch at SW1 will provide a signal when the tool is at datum.

Kit Types for A1 blocks

Code	Part No.	Control Block	Solenoid Valves	Proximity switches
C03	104002	A1 (M8)		2 x M8 PNP + Cables
C05	104842	A1 (M8)		2 x M8 NPN + Cables
C10	438223	A1 (M8)	2 x NC	2 x M8 PNP + Cables
C11	438233	A1 (M8)	1 x NO, 1 x NC	2 x M8 PNP + Cables
C12	438243	A1 (M8)	2 x NC	2 x M8 NPN + Cables

Individual Proximity Switch Part Numbers & Specifications

Proximity Switch Type	Part Number	Operating Voltage	Voltage Drop	Rated Operating Current	Operating Temperature
M8 PNP NO	381223	10-30V	<=2.5V	250mA	-25 to 70 C
PNP Cable	381233				
M8 NPN NO	396183	10-30V	<=2.5V	250mA	-25 to 70 C
NPN Cable	397043				

Cable Connections 24V (Brown) to 24V 0V (Blue) to 0V Output (Black)

The output is short circuit protected (pulsed). After elimination of the short circuit the switch is ready again for operating.

Solenoid Valve Part Numbers & Specifications (Supplied with DIN style plug – no cable)

Solenoid Valve Type	Part Number	Rated Voltage	Rated Power
NO	396263	24V	2W
NC	326753	24V	1W

Feed Control - Hydraulic Control Unit (HCU) Mounting and Use

Allow rapid advance under air pressure then a controlled feed up to the stroke of the HCU
 They also reduce burring on the exit side of the hole by preventing the tool from "jumping" through the hole when the drilling pressure is relieved. It also eliminates the possibility of the drill unit stalling as it "breaks through"

To fit the HCU – Remove the plastic cover (2 socket head cap screws) to reveal the HCU mounting bracket (also for stroke adjustment). Slide the HCU into the bracket – ensure the flat on the HCU lines up with the flat on the bracket. The groove on the HCU should be just below the bracket – ensure it does NOT prevent the fine stroke adjustment screw from touching the depth valve – the tool will NOT return if this happens. To refit the cover there is a knock-out that has to be removed by hand or with pliers.

Max Dimension X	D1-1"	D2-2"	D3-3"
AFD205/215			
AFD415			
AFDE200 >=2350	2.7"	4.7"	6.7"
AFDE400 >=900			
AFDE600 >=900			
AFDE400 <=550	0	1.9"	3.9"
AFDE600 <=550			

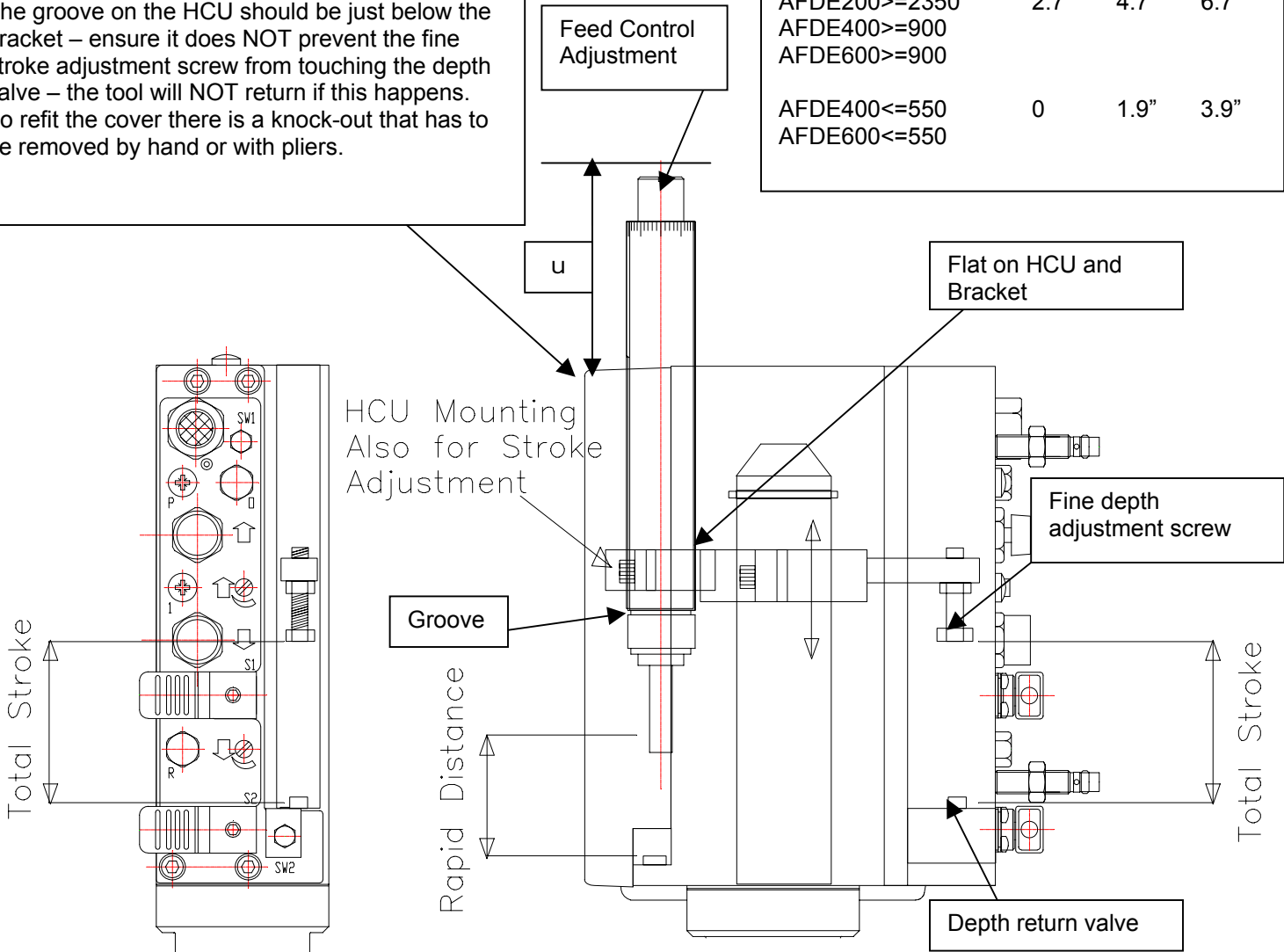

Standard Available
 HCU's
 D1 - 1"
 D2 - 2"
 D3 - 3"