

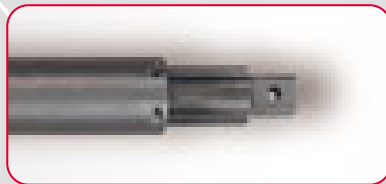

# Pneumatic Torque Motors



# Contents and Torque Motor Selection

## Contents

Torque Motor Selection ..... *page 2*

Torque Controlled Shut Off..... *page 4*

    SC Series..... *page 4*

    SD Series..... *page 6*

    F Series..... *page 8*

    Accessories ..... *page 10*

System 100, Stall Torque ..... *page 12*

    DM Series..... *page 12*

    HM Series..... *page 14*

    2HM5-HT Series. *page 16*

System 200/300, MTI/ITC..... *page 17*

Screwfeeding Systems..... *page 20*

Stands..... *page 21*

Slide Feed Units and Multiple Units... *page 22*









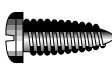

Other Assembly and Automation Products..... *page 23*

## Torque Motor Selection

### Criteria

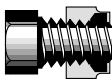
- Type of Fastener/Component
- Joint Integrity
- Torque Required

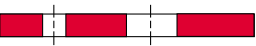
### TYPE OF FASTENER/COMPONENT

Fastener/Component		Recommended Tool Type
Machine Screw/Nut		All Systems
Thread Rolling/Forming		All Systems
Self Tapping		System 100/200
Self Tapping in Plastic/Thin Materials		Torque Controlled Shut Off
Self Drilling		System 100/200
Wood Screws		System 100/200
Screws with Adhesive		System 300 with dual pressure control
Self Lock Nuts		System 300 with dual pressure control
Misaligned Holes		System 300 with dual pressure control
Variable Size Holes		System 300 with dual pressure control
Fragile Components		System 300 with 2 speed control

# Torque Motor Selection

## JOINT INTEGRITY

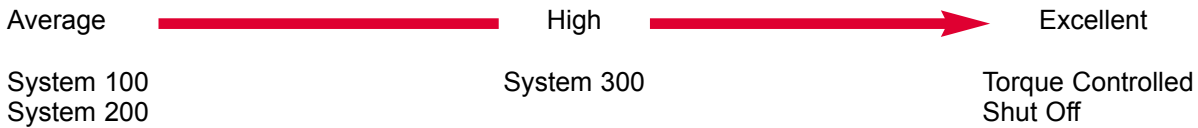

The Desoutter range of Torque Motors includes 4 options of torque control.

### Torque Controlled Shut Off – 3.5 inlb - 23.6 ftlb (0.4-32 Nm)



These tools feature the Desoutter Target Tork clutch that operates a shut-off valve built into the tool. The low friction rolling action of the clutch dogs together with the synchronous air shut-off can provide torque repeatability's greater than  $\pm 5\%$  depending on the joint.

### System 100 – Stall Torque – 1.5-129 ftlb (2-175 Nm)



With this system the motors are controlled by regulating the air pressure.

Stall torque is the best method of torque control for the majority of joints of a non critical nature and torque repeatability of  $\pm 10\%$  can be readily achieved with a consistent air supply.

### System 200 – Minimum Torque Indication (MTI) – 6.6-129 ft lb (9-175 Nm)



System 200 is used where a signal is required to show that the minimum torque required has been achieved.

The motor is mounted on a caliper which incorporates a torque reaction spring of a known value. The fixed part of the caliper is bolted to the base plate of the unit whilst the motor is mounted onto the moving part of the caliper.

When the motor stalls out the caliper closes and provided the minimum torque has been achieved, closes a valve or switch. The signal can be used to provide a visual indication, signal a PLC or other ancillary equipment.

### System 300 – Indicated Torque Control (ITC) – 6.6-129 ftlb (9-175 Nm)

When more accurate control of torque is required, outside the scope of stall torque, some means of motor shut-off must be used so the motors can be stopped when the torque has been achieved. Desoutter System 300 is designed to shut-off the motors when the desired torque has been reached. It uses the same caliper system as System 200, but the signal from the caliper is used to switch a shuttle valve, controlling air entry into the motor. The signal from the valve can also be used to operate other equipment.

The ITC System is not subject to error due to air pressure fluctuation as motors can operate at higher pressure settings than would be used when operating the motor under stall conditions. This also means that faster cycle times can be achieved.

# Torque Controlled Shut Off – SC Series

A



## PUSH START – SHUT OFF – ONE WAY

PICTURE REF	TOOL TYPE	PART NUMBER	FREE SPEED	TORQUE RANGE	FITTED SPRING	AIR FLOW	AIR HOSE BORE	AIR INLET	SOUND LEVEL	VIBRATION
			r/min	in lb	in lb	cfm	in.	NPT	dB(A)	ms <sup>2</sup>
A	ASPC021-1A2300-S4Q	1458774	2300	3.5-18.5	3.5-7.9	14.80	1/4"	1/8"	75	<2.5
A	ASPC021-1A1600-S4Q	1458784	1600	3.5-25.6	5.3-18.5	14.80	1/4"	1/8"	75	<2.5
A	ASPC043-1A1100-S4Q	1458794	1100	3.5-37.1	7.9-37.1	14.80	1/4"	1/8"	75	<2.5
A	ASPC047-1A550-S4Q	1458804	550	3.5-39.8	7.9-39.8	14.80	1/4"	1/8"	75	<2.5

## REMOTE START – SHUT OFF – TWO WAY

PICTURE REF	TOOL TYPE	PART NUMBER	FREE SPEED	TORQUE RANGE	FITTED SPRING	AIR FLOW	AIR HOSE BORE	AIR INLET	SOUND LEVEL	VIBRATION
			r/min	in lb	in lb	cfm	in.	NPT	dB(A)	ms <sup>2</sup>
A	ASPC021-2A2300-S4Q	1458814	2300	3.5-18.5	3.5-7.9	14.80	1/4"	1/8"	75	<2.5
A	ASPC021-2A1600-S4Q	1458824	1600	3.5-26.5	5.3-18.5	14.80	1/4"	1/8"	75	<2.5
A	ASPC043-2A1100-S4Q	1458834	1100	3.5-38.0	7.9-38.0	14.80	1/4"	1/8"	75	<2.5
A	ASPC047-2A550-S4Q	1458844	550	3.5-39.8	8.8-39.8	14.80	1/4"	1/8"	75	<2.5

## Pneumatic Control

Remote start tools will start as soon as air is supplied to the forward or reverse port.

Pressure tapping gives a 3 bar signal while tool is running. Signal stops when the clutch operates.

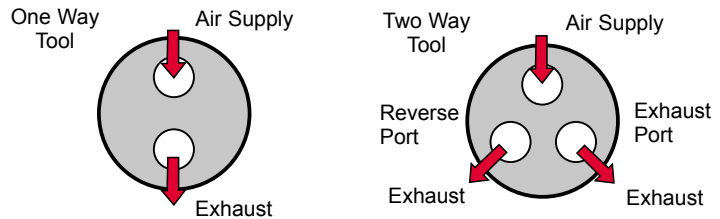

## Torque Range and Spring Selection

To obtain the torque required the clutch spring may have to be changed. There are 3 spring types, white, black and natural. The torque ranges are shown in the table below:

SPRING	TORQUE RANGE	TOOL TYPES
	in lb	
White	3.5-7.9	All Models
Black	5.3-17.7	ASPC047
	5.3-18.5	ASPC021
	5.3-19.5	ASPC043
Natural	8.8-25.6	ASPC021-1A1600
	8.8-26.5	ASPC021-2A1600
	7.9-37.1	ASPC043-1A1100
	7.9-38.0	ASPC043-2A1100
	7.9-39.8	ASPC047-1A550
	8.8-39.8	ASPC047-2A550

# SC Series – Dimensions

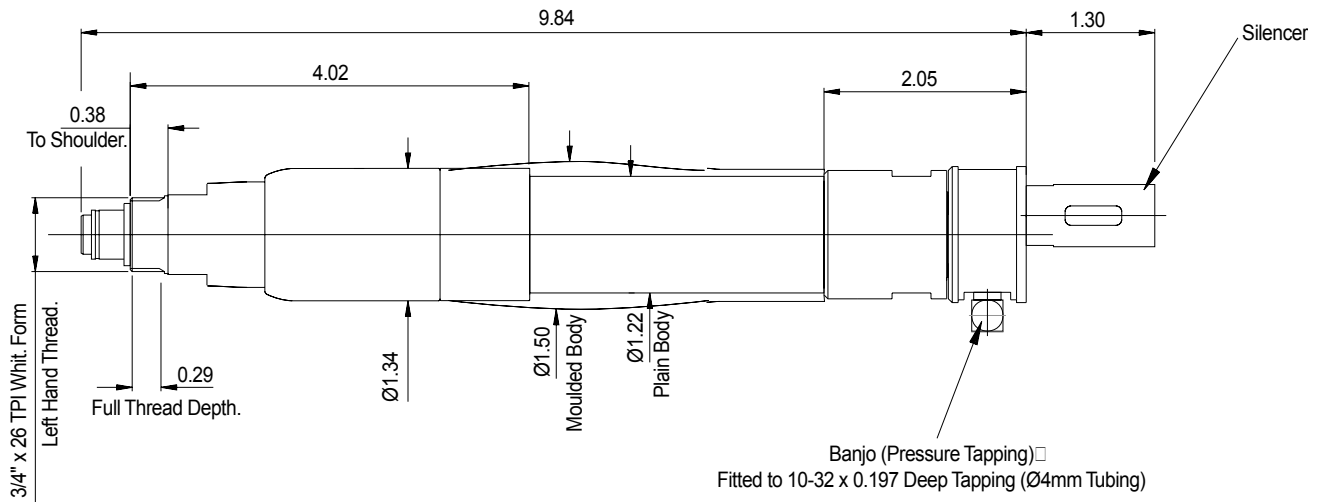

1 Way tool Only Is Offered With Either Moulded Or Plain Motor Case

Weight 1.5lb (0.68kg)

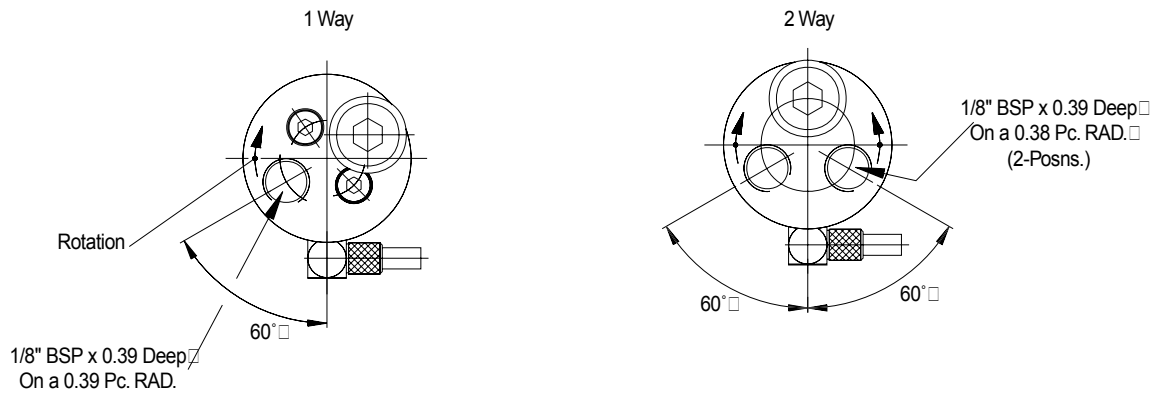

All dimensions are in inches calculated from measured millimeter values

# Torque Controlled Shut Off – SD Series



## PUSH START – SHUT OFF – ONE WAY

PICTURE REF	TOOL TYPE	PART NUMBER	FREE SPEED	TORQUE RANGE	FITTED SPRING	AIR FLOW	AIR HOSE BORE	AIR INLET	SOUND LEVEL	VIBRATION
			r/min	in lb	in lb	cfm	in.	NPT	dB(A)	ms <sup>2</sup>
A	SD023-1AM3500-S4Q	1464254	3500	8.9-20.4	8.9-20.4	18.40	1/4"	1/8"	73	<2.5
A	SD035-1AM2200-S4Q	1464244	2200	8.9-40.0	8.9-40.0	18.40	1/4"	1/8"	73	<2.5
A	SD055-1AM1470-S4Q	1464234	1470	17.7-48.7	17.7-48.7	18.40	1/4"	1/8"	73	<2.5
A	SD075-1AM1100-S4Q	1464224	1100	22.1-66.4	22.1-66.4	18.40	1/4"	1/8"	73	<2.5
A	SD100-1AM820-S4Q	1464214	820	31.0-88.5	31.0-88.5	18.40	1/4"	1/8"	73	<2.5
A	SD140-1AM510-S4Q	1464204	510	31.0-123.9	31.0-88.5	18.40	1/4"	1/8"	73	<2.5
A	SD160-1AM320-S4Q	1464194	320	31.0-141.6	31.0-88.5	18.40	1/4"	1/8"	73	<2.5

## REMOTE START – SHUT OFF – MANUAL REVERSE

PICTURE REF	TOOL TYPE	PART NUMBER	FREE SPEED	TORQUE RANGE	FITTED SPRING	AIR FLOW	AIR HOSE BORE	AIR INLET	SOUND LEVEL	VIBRATION
			r/min	in lb	in lb	cfm	in.	NPT	dB(A)	ms <sup>2</sup>
B	SD023-2RM3500-S4Q	1464324	3500	8.9-20.4	1.0-2.3	18.40	1/4"	1/8"	73	<2.5
B	SD035-2RM2200-S4Q	1464314	2200	8.9-40.0	1.0-3.5	18.40	1/4"	1/8"	73	<2.5
B	SD055-2RM1470-S4Q	1464304	1470	17.7-48.7	17.7-48.7	18.40	1/4"	1/8"	73	<2.5
B	SD075-2RM1100-S4Q	1464294	1100	22.1-66.4	22.1-66.4	18.40	1/4"	1/8"	73	<2.5
B	SD100-2RM820-S4Q	1464284	820	31.0-88.5	31.0-88.5	18.40	1/4"	1/8"	73	<2.5
B	SD140-2RM510-S4Q	1464274	510	31.0-123.9	31.0-88.5	18.40	1/4"	1/8"	73	<2.5
B	SD160-2RM320-S4Q	1464264	320	31.0-141.6	31.0-88.5	18.40	1/4"	1/8"	73	<2.5

## Pneumatic Control

Both tools produce signals for interfacing with other equipment.

10-32 Port provides signal while tool is running. The signal stops when the clutch operates.



## Torque Range and Spring Selection

The majority of the SD Series uses one spring to cover the entire torque range. The 320 and 510 r/min tools use two springs as per below.

SPRING	TOOL SPEED	
	510	320
465763	31.0-88.5	31.0-88.5
465753	66.4-123.9	66.4-141.6

# SD Series – Dimensions

## SD-1AM

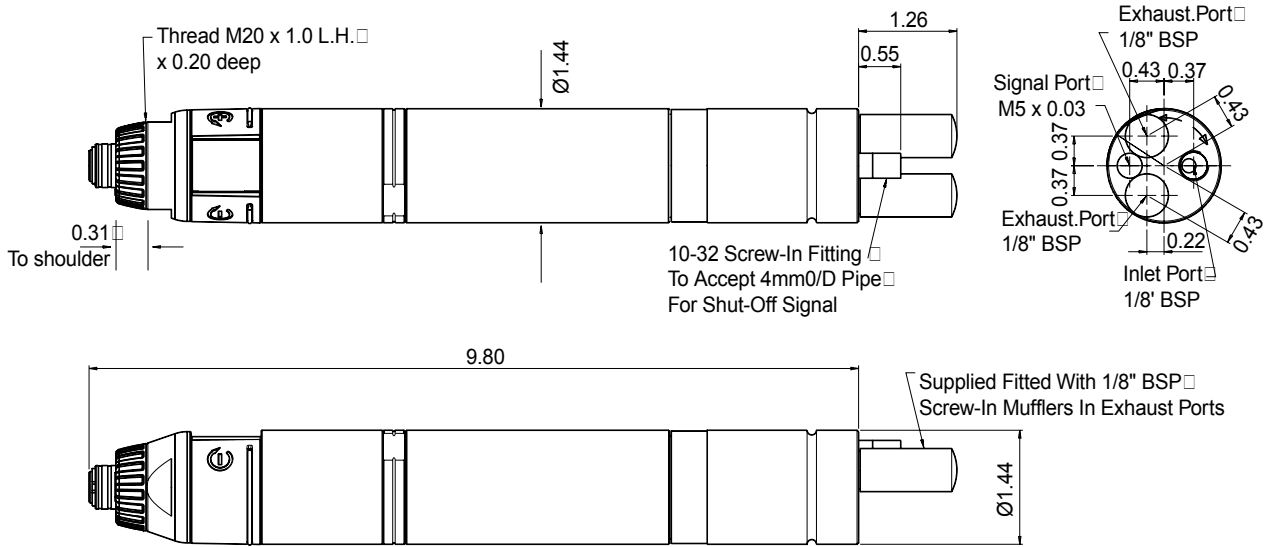

### Weights

1AM (320, 510, 820, 1100 & 1470rpm) = 2.02lb (0.92kg)  
 1AM (2200 & 3500 rpm) = 1.67lb (0.76kg)

## SD-2RM

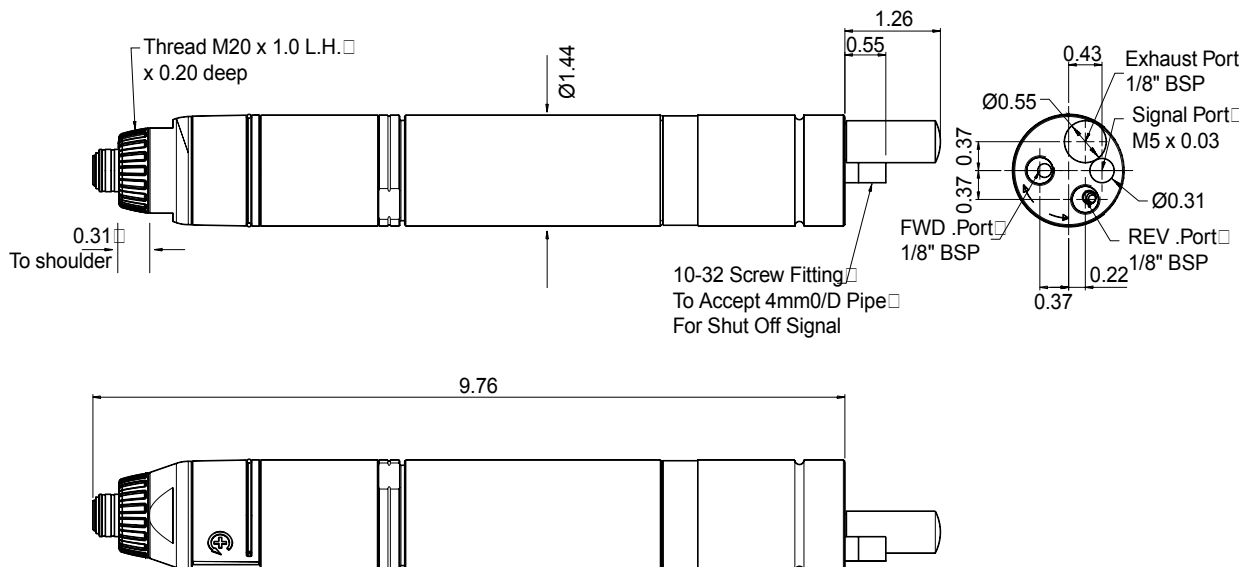

All dimensions are in inches calculated from measured millimeter values

### Weights

2RM (320, 510, 820, 1100 & 1470rpm) = 2.02lb (0.92kg)  
 2RM (2200 & 3500 rpm) = 1.67lb (0.76kg)

# Torque Controlled Shut Off – F Series

A

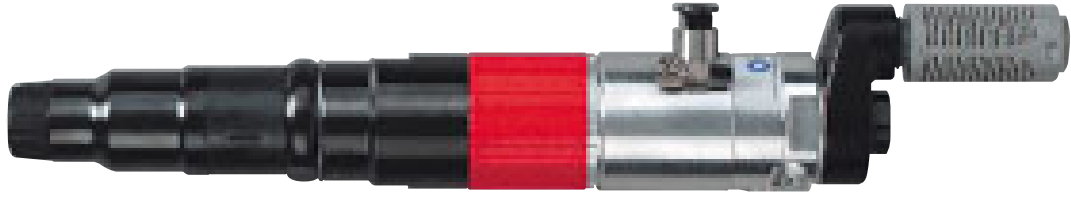

B



## PUSH START – SHUT OFF – MANUAL REVERSE

PICTURE REF	TOOL TYPE	PART NUMBER	FREE SPEED	TORQUE RANGE	FITTED SPRING	AIR FLOW	AIR HOSE BORE	AIR INLET	SOUND LEVEL	VIBRATION
			r/min	ft lb	ft lb	cfm	in.	NPT	dB(A)	ms <sup>2</sup>
A	2F89-AX-900	1462594	900	2.1-6.2	2.1-6.2	21.2	3/8"	1/4"	76	<2.5
A	2F89-AX-630	1462584	630	2.6-8.8	2.6-8.8	21.2	3/8"	1/4"	76	<2.5
B	2F89-AX-260	1462574	260	7.7-23.6	16.2-23.6	21.2	3/8"	1/4"	76	<2.5

Outputs – 630/900rpm, 1/4" hex  
 – 260rpm, 3/8" square

## Pneumatic Control

The 2F89 tools produce a signal while the tool is running for interfacing with other equipment. The signal stops when the clutch operates.

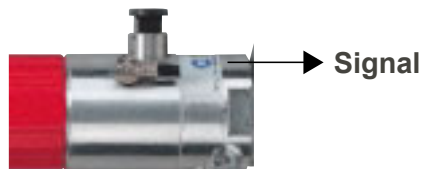

# F Series – Dimensions

## 2F89-AX-630/900

900 r/min

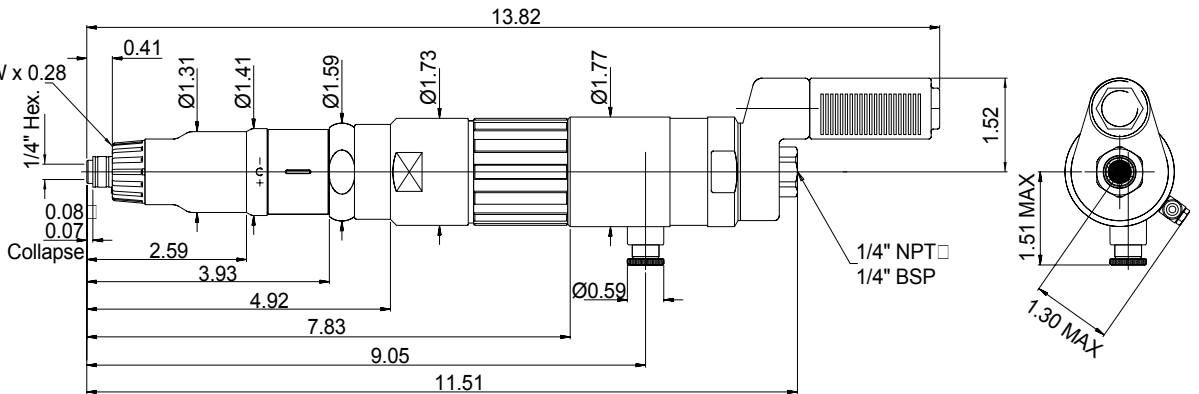

630 r/min

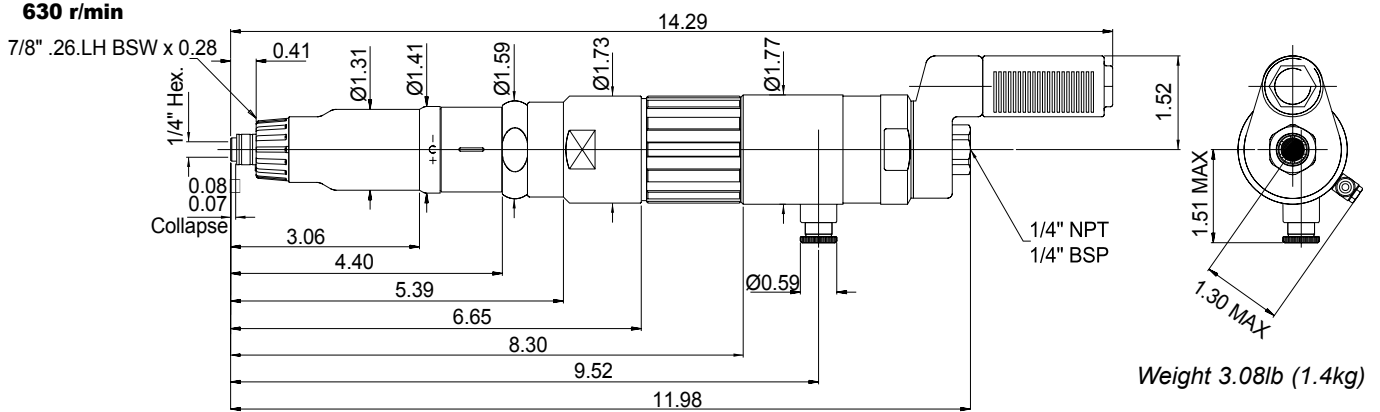

Weight 3.08lb (1.4kg)



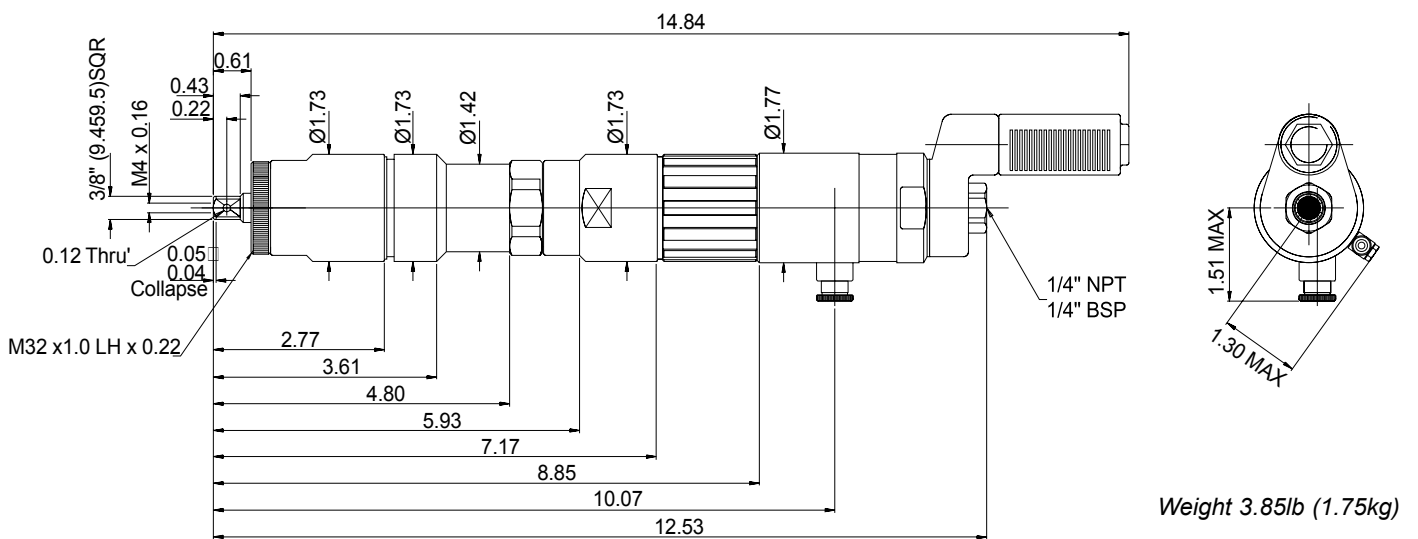



## 2F89-AX-260

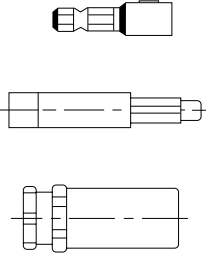

Weight 3.85lb (1.75kg)

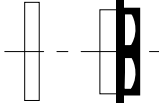
All dimensions are in inches calculated from measured millimeter values

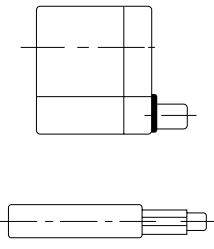
# Torque Controlled Shut Off – Accessories

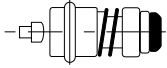
Accessories	ITEM	SC SERIES	SD SERIES	F SERIES
<p><b>Spring Loaded Shafts and Bearing Supports</b></p>  <p>Provides a rigid output drive and mounting for use in single or multi spindle assembly units.</p>		<p>103782</p> <p>108342</p> <p>103742</p>	<p>103782</p> <p>108342</p> <p>108412</p>	<p>103782</p> <p>108342</p> <p>103752</p>
<p><b>Nose Mounts</b></p>  <p>Mounting to allow torque motors to be mounted squarely on a plate (not required if a bearing support is used).</p>		<p>103722</p>	<p>108392</p>	<p>103732</p>
<p><b>Offset Heads</b></p>  <p>Offset head and output spindle for applications with close centres (minimum 0.748" (19mm)).</p>		<p>384993</p> <p>108352</p>	<p>384993</p> <p>108352</p>	<p>–</p> <p>–</p>
<p><b>Screwdriver Bit Adaptor</b></p>  <p>Quick release bit adaptor for use with the output shafts above. Provides a 1/4" hex output.</p>		<p>108322</p>	<p>108322</p>	<p>108322</p>

# Torque Controlled Shut Off – Accessories

**108342/  
108352**

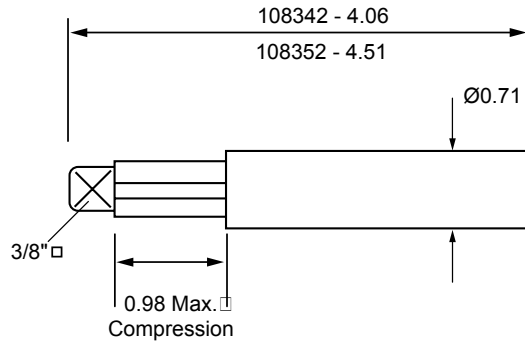

**130742/108412**

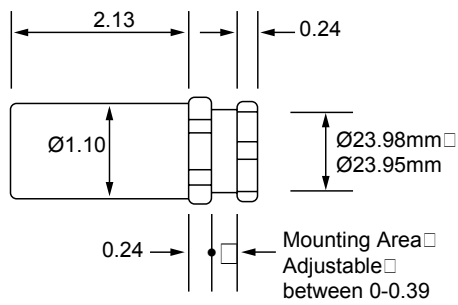

**103752**

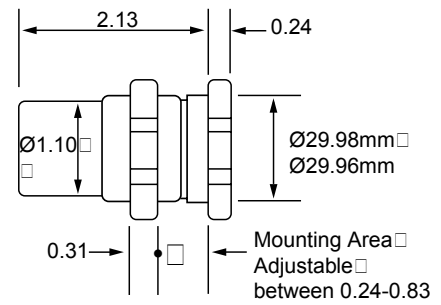

**384993**

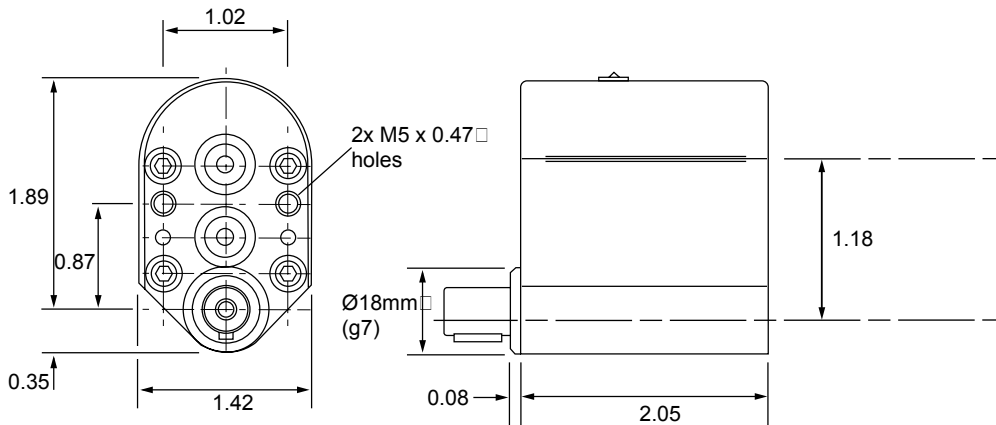

**103722/103732/108392**

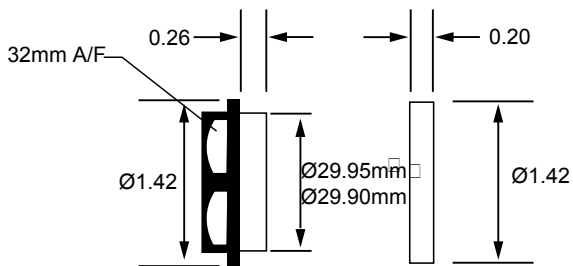

**108322**

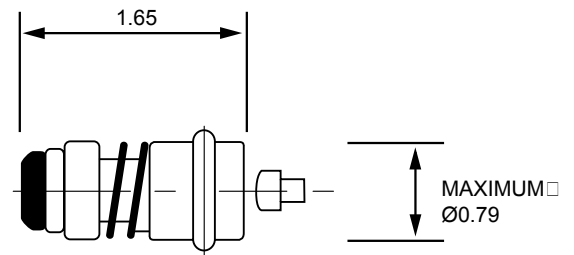

All dimensions are in inches calculated from measured millimeter values unless otherwise stated

# System 100 – DM Series



## SPECIFICATION

PIC REF	TOOL TYPE	MOTOR ROTATION	AIR FLOW AT 6.3 BAR	AIR HOSE BORE	SOUND LEVEL	VIBRATION
			cfm	in.	dB(A)	ms <sup>2</sup>
A	DM6	One Way	19.90	3/8"	76	<2.5
B	2DM6	Two Way	19.90	3/8"	73	<2.5

## TORQUES (ft lb)

AIR PRESSURE		FREE SPEED				
bar	psi	290	390	620	980	1650
6	87	–	–	–	7.67	4.50
5	75	–	–	–	6.42	3.76
4	58	–	–	8.48	5.16	3.02
3	43	–	8.85	6.12	3.91	2.21
2	29	6.64	5.90	4.06	2.58	1.48

**Maximum stall torque 8.9 ftlb**  
 Data obtained from a lubricated air line  
 Torque figures are to be used as a guide only

## Pneumatic Control

Tools will start as soon as air is supplied to the forward or reverse port.

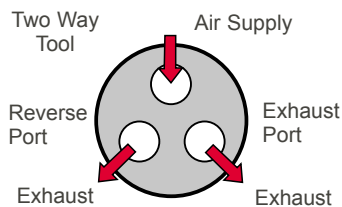

## HOW TO ORDER

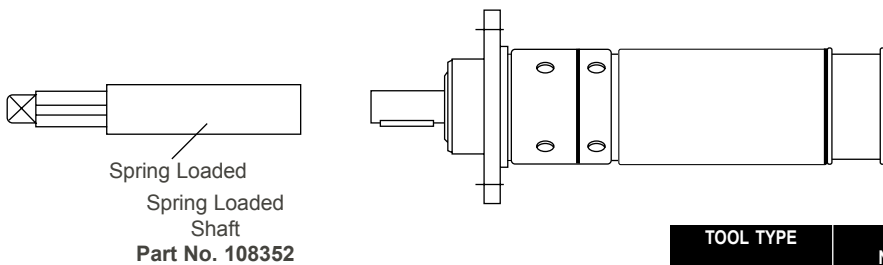

TOOL TYPE	PART NUMBER	TOOL TYPE	PART NUMBER
DM6-290T	1454214	2DM6-290	1414164
DM6-390T	1454204	2DM6-390	1414244
DM6-620T	1454194	2DM6-620	1413774
DM6-980T	1454184	2DM6-980	1414084
DM6-1650T	1454304	2DM6-1650	1416604



# System 100 – HM Series

A



B



## REMOTE START – TWO WAY SPECIFICATION

PIC REF	TOOL TYPE	AIR FLOW AT 6.3 BAR	AIR HOSE BORE	SOUND LEVEL	SOUND POWER LEVEL	VIBRATION
		cfm	in.	dB(A)	dB(A)	ms <sup>-2</sup>
A	2HM5	35.0	3/8"	89	100	<2.5
B	2HM5 with Offset Head	35.0	3/8"	89	100	<2.5

## REMOTE START – TWO WAY TORQUES (ft lb)

AIR PRESSURE		FREE SPEED			
bar	psi	150	350	550	950
6	87	–	–	30.24	18.44
5	75	–	36.88	24.34	15.49
4	58	–	29.50	19.18	11.80
3	43	–	22.13	14.75	8.85
2	29	36.88	15.49	10.33	6.64

**Maximum stall torque 37.6 ftlb**

Data obtained from a lubricated air line

Torque figures are to be used as a guide only

## Pneumatic Control

Tools will start as soon as air is supplied to the forward or reverse port.

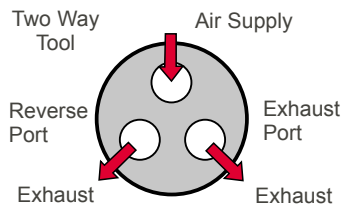

## HOW TO ORDER

### 2DM6

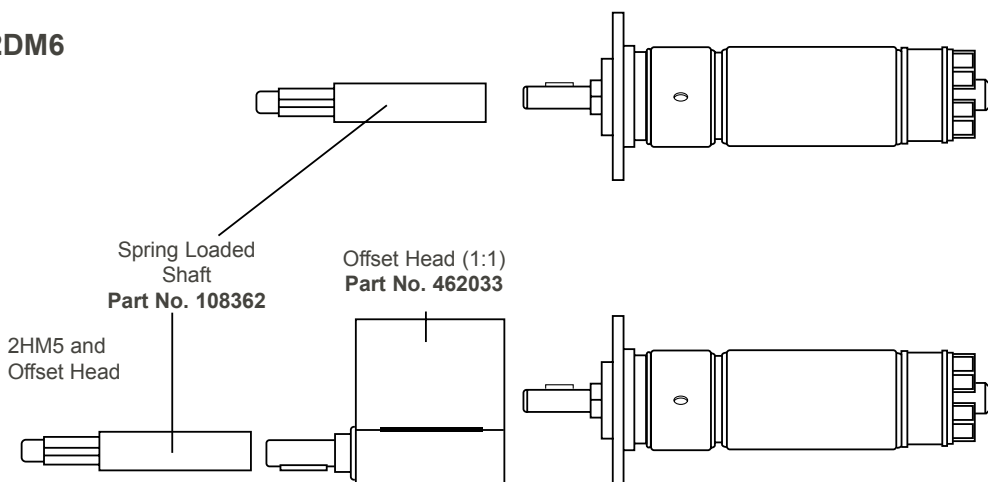

TOOL TYPE	PART NUMBER
2HM5-150	1309284
2HM5-350	1309444
2HM5-550	1309524
2HM5-950	1309604

# HM Series – Dimensions

## 2HM5

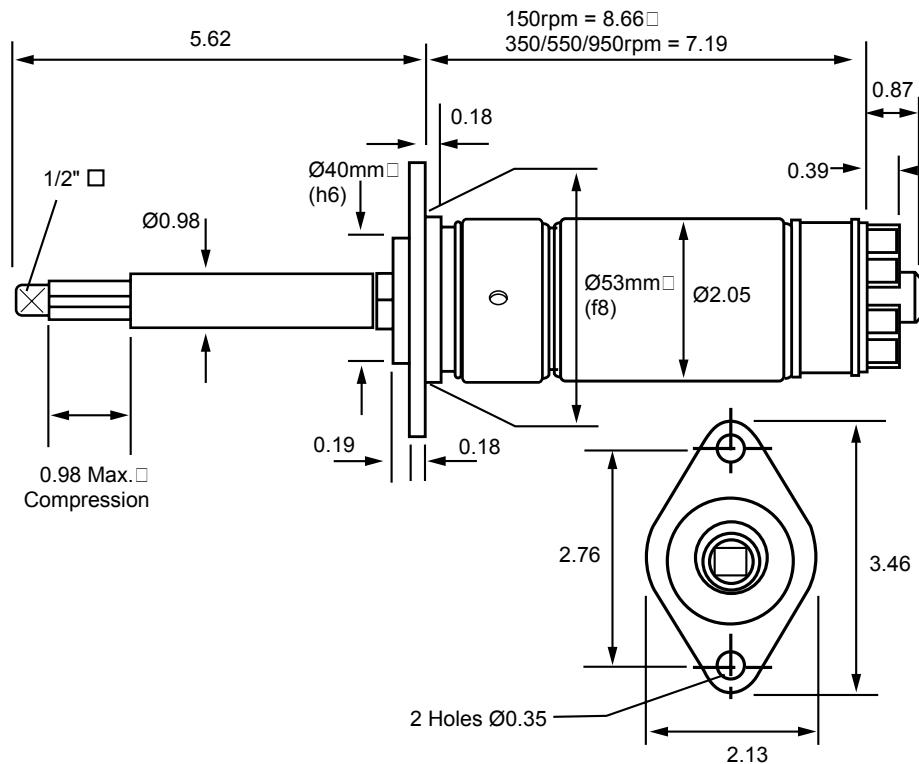

## 2HM5 and Offset Head

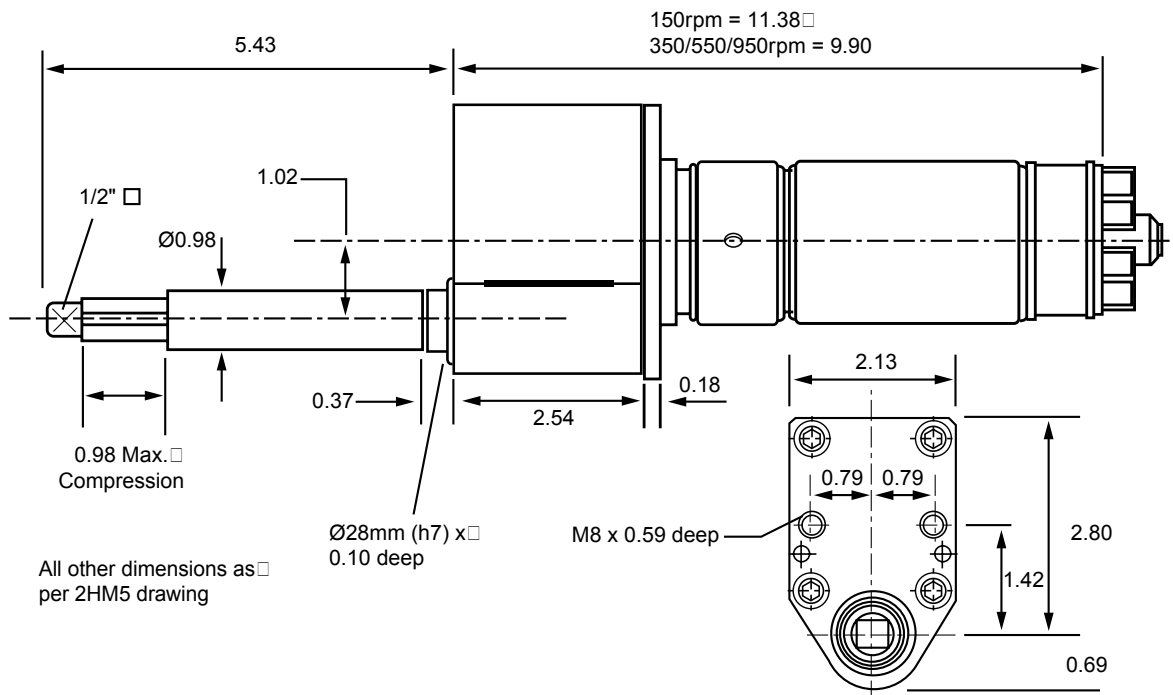

All dimensions are in inches calculated from measured millimeter values unless otherwise stated

# System 100 – 2HM5-HT Series

A



## REMOTE START – TWO WAY

PICTURE REF	TOOL TYPE	PART NUMBER	FREE SPEED <sup>(1)</sup>	TORQUE RANGE	AIR FLOW <sup>(1)</sup>	AIR HOSE BORE	AIR INLET	SOUND LEVEL	SOUND POWER LEVEL	VIBRATION
			r/min	ft lb	cfm	in.	NPT	dB(A)	dB(A)	ms <sup>-2</sup>
A	2HM5-HT-230	1462654	230	22-62	35.0	3/8"	1/4"	89	100	<2.5
A	2HM5-HT-130	1462644	130	36-103	35.0	3/8"	1/4"	89	100	<2.5
A	2HM5-HT-80	1462634	80	55-129	35.0	3/8"	1/4"	89	100	<2.5

<sup>(1)</sup> Values taken at 6.3 bar inlet pressure

### TORQUES (ft lb)

AIR PRESSURE		FREE SPEED		
bar	psi	80	130	230
6	87	–	103.26	62.69
5	75	125.39	84.82	51.63
4	58	99.57	66.38	40.57
3	43	73.76	51.63	33.19
2	29	55.32	36.88	22.13

### Maximum stall torque 129 ftlb

Data obtained from a lubricated air line  
Torque figures are to be used as a guide only

### Pneumatic Control

Tools will start as soon as air is supplied to the forward or reverse port.

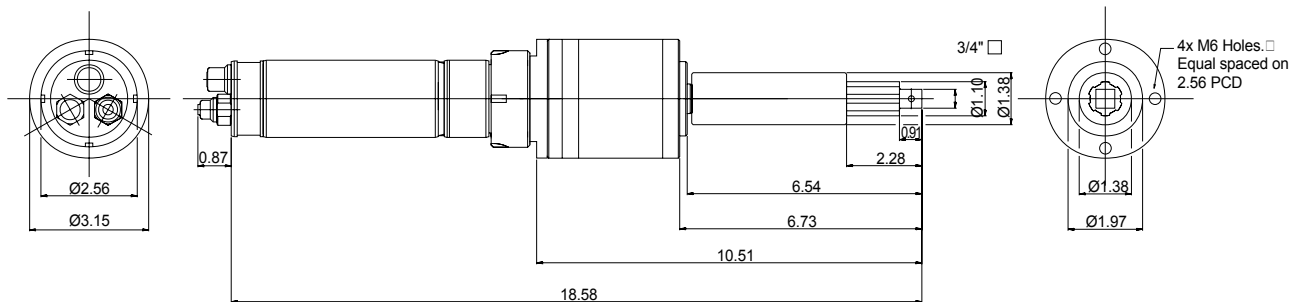
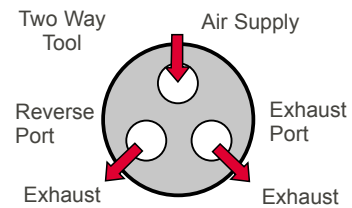

Collapsed View

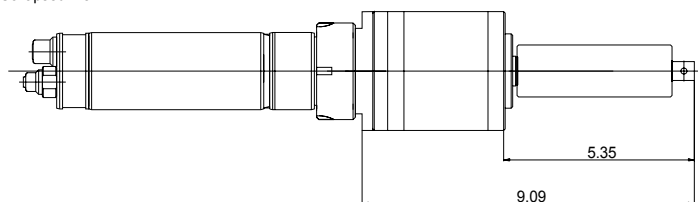

Weight 12.54lb (5.7kg)

All dimensions are in inches  
calculated from measured millimeter  
values unless otherwise stated

# System 200/300 – 2HM5-MTI/ITC

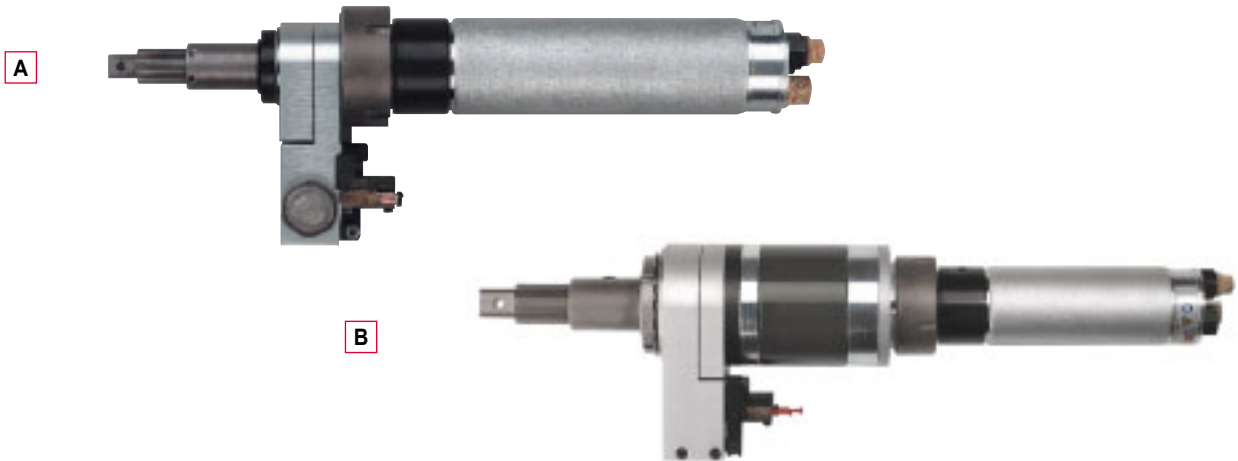

## REMOTE START – ONE WAY

PICTURE REF	TOOL TYPE	PART NUMBER	FREE SPEED <sup>(1)</sup>	TORQUE RANGE	AIR FLOW <sup>(1)</sup>	AIR HOSE BORE	AIR INLET	SOUND LEVEL	SOUND POWER LEVEL	VIBRATION
			r/min	ft lb	cfm	in.	NPT	dB(A)	dB(A)	ms <sup>-2</sup>
A	2HM5-550-MTI/ITC	1462624	550	11.1-30.2	35.0	3/8"	1/4"	89	100	<2.5
A	2HM5-350-MTI/ITC	1462614	350	15.5-37.6	35.0	3/8"	1/4"	89	100	<2.5
A	2HM5-150-MTI/ITC	1462604	150	33.2-37.6	35.0	3/8"	1/4"	89	100	<2.5
B	2HM5-HT-230-MTI/ITC	1462684	230	22.0-62.0	35.0	3/8"	1/4"	89	100	<2.5
B	2HM5-HT-130-MTI/ITC	1462674	130	36.0-103.0	35.0	3/8"	1/4"	89	100	<2.5
B	2HM5-HT-80-MTI/ITC	1462664	80	55.0-129.0	35.0	3/8"	1/4"	89	100	<2.5

<sup>(1)</sup> Values taken at 6.3 bar inlet pressure

### 2HM5 TORQUES (ft lb)

AIR PRESSURE		FREE SPEED		
bar	psi	150	350	550
6	87	–	–	30.24
5	75	–	36.88	24.34
4	58	–	29.50	19.18
3	43	–	22.13	14.75
2	29	36.88	15.49	10.33

### 2HM5-HT TORQUES (ft lb)

AIR PRESSURE		FREE SPEED		
bar	psi	80	130	230
6	87	–	103.26	62.69
5	75	125.39	84.82	51.63
4	58	99.57	66.38	40.57
3	43	73.76	51.63	33.19
2	29	55.32	36.88	22.13

**Maximum stall torque 37.6 ftlb**

Data obtained from a lubricated air line  
Torque figures are to be used as a guide only

**Maximum stall torque 129 ftlb**

## HOW TO ORDER

PICTURE REF	SWITCH/VALVE	PART NUMBER
A	Pneumatic	108952
A	Electric	108962

PICTURE REF	TOOL TYPE	PART NUMBER
B	2HM5-550-MTI/ITC	1462624
B	2HM5-350-MTI/ITC	1462614
B	2HM5-150-MTI/ITC	1462604
B	2HM5-HT-230-MTI/ITC	1462684
B	2HM5-HT-130-MTI/ITC	1462674
B	2HM5-HT-80-MTI/ITC	1462664

# System 200/300 – Control Circuits

## SYSTEM 200

Indicating Light

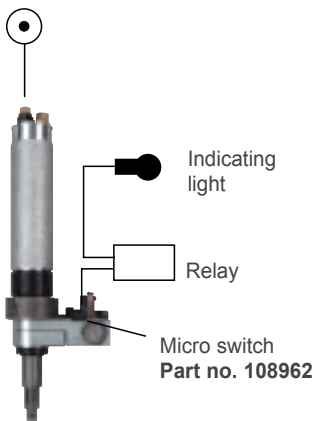

Pneumatic Indicator

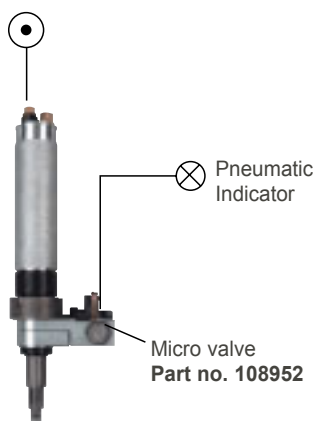

Signal to PLC

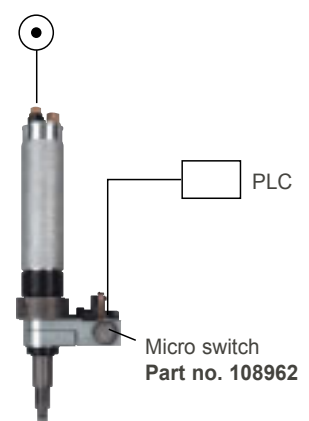

## SYSTEM 300

Pneumatic Control

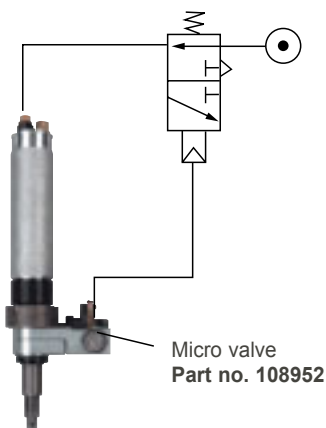

Electric Control

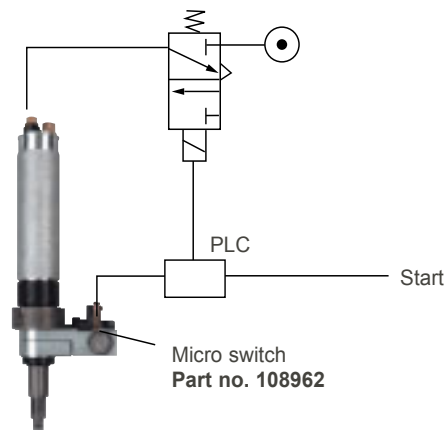

Electric Control with 2 Speed Cycle

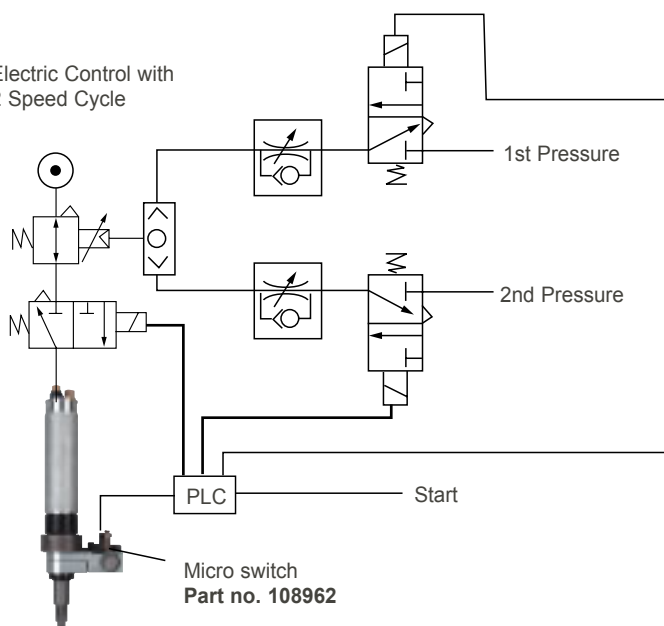

### Notes:

- Ensure that any valves and tubing used with the torque motors have the appropriate air flow rating.
- Avoid using pneumatic lubricating oil in any control circuit.
- For high torques, it may be necessary to introduce a short pulse (<1 sec) of low pressure (<2 bar) air onto the reverse port to permit the socket to disengage from the fastener.

# 2HM5-MTI/ITC Series – Dimensions

## 2HM5-MTI/ITC

2HM5-350/550MTI/ITC

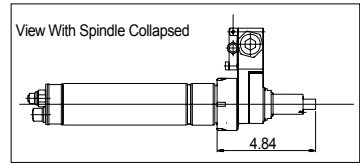
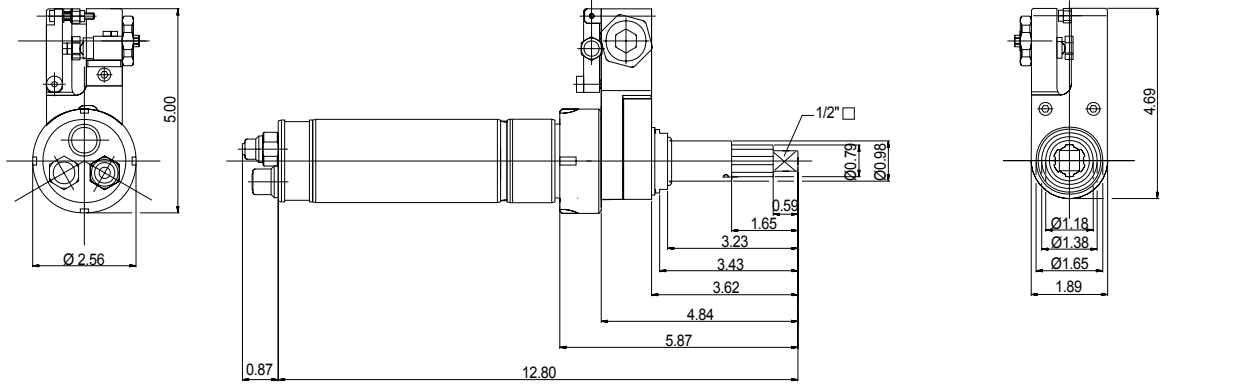

2HM5-150 MTI/ITC

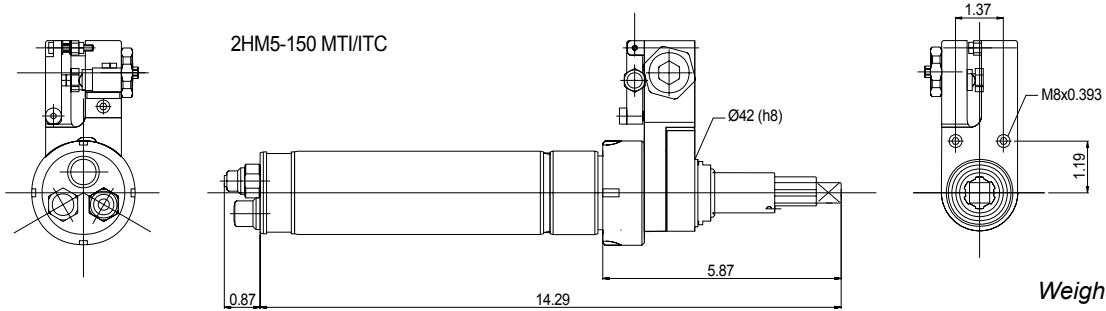

Weight 7.48lb (3.4kg)

## 2HM5-HT-MTI/ITC

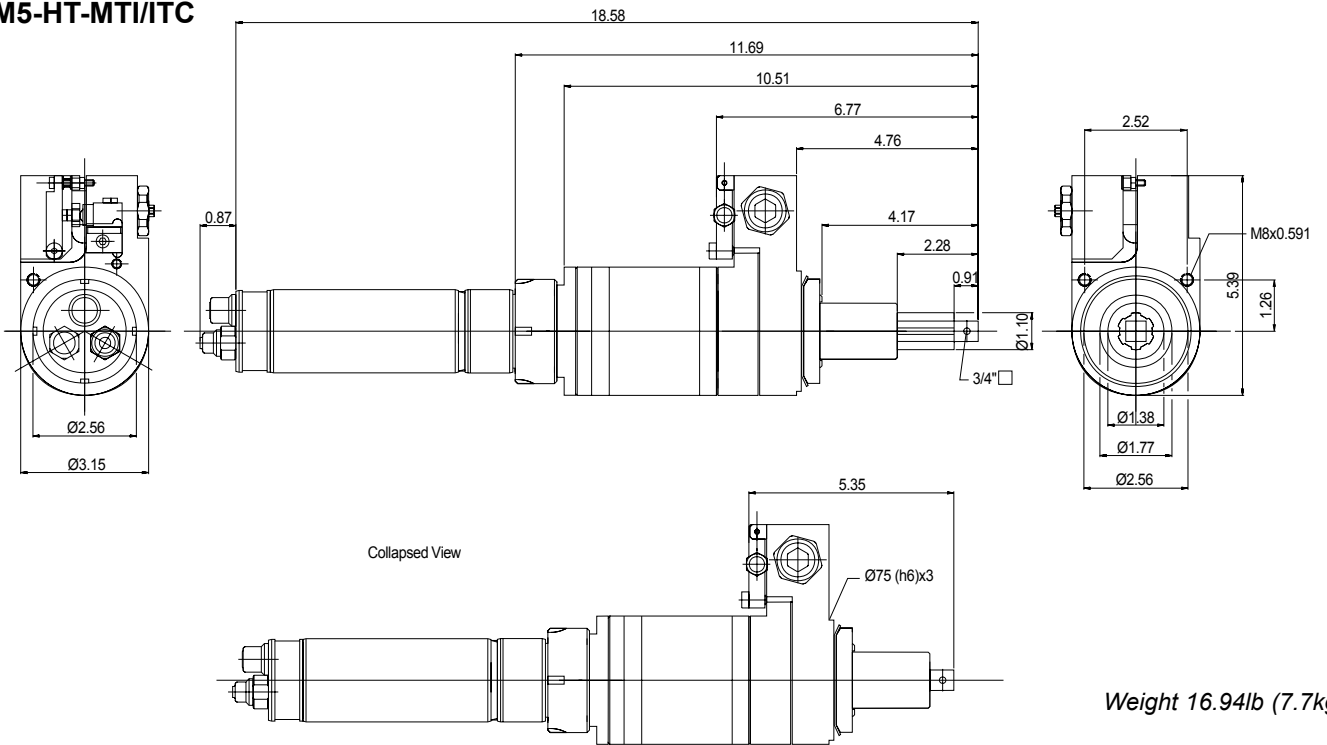

Weight 16.94lb (7.7kg)

All dimensions are in inches calculated from measured millimeter values unless otherwise stated

# Screwfeeding Systems



For applications where productivity is of importance the use of a screwfeeder can dramatically reduce the fastening cycle time.

The range of Desoutter Screw Feeding Systems are capable of operation with hand operated and fixtured tools.

Ask for further details from your local sales contact.

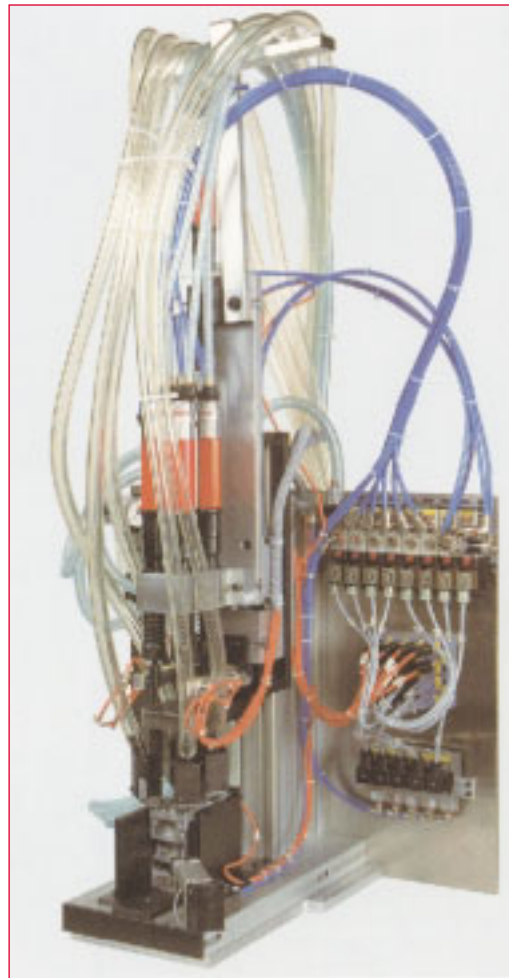

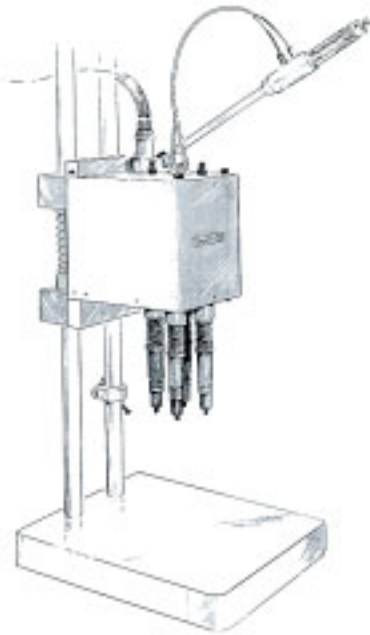

## MC55 Cylinder-Operated Stand With Linear Bearings

Part No. 902914  
 Weight: 70.4lb (32kg)  
 Max. Stroke: 4 in. (100mm)  
 Max. Mounting Plate Load: 150lb (68kg)

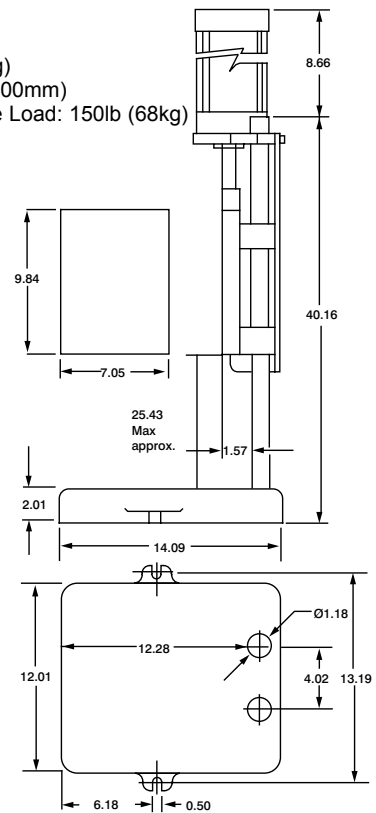

Lever operated version of the MC55 is available upon request.

Mounting Brackets can be made to order for the R55-S and MC55.

## D54 Lever-Operated Stand For SD, DM6, 2DM6 Motors

Part No. 901944  
 Weight: 15.4lb (7kg)  
 Max. Stroke: 1.77 in. (45mm)

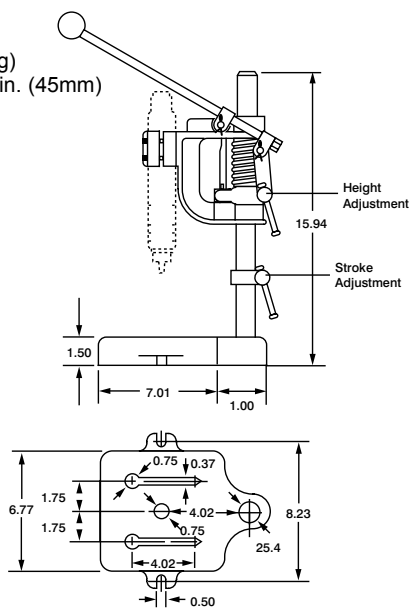

## R55-S Lever-Operated Stand

Part No. 903644  
 Weight: 24.9lb (11.32kg)  
 Max. Stroke: 2.24 in. (57mm)  
 Max. Mounting Plate Load: 13.2lb (6kg)

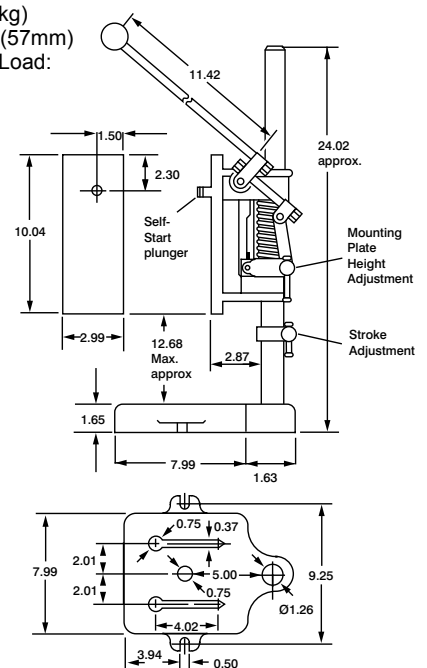

All dimensions are in inches calculated from measured millimeter values unless otherwise stated