

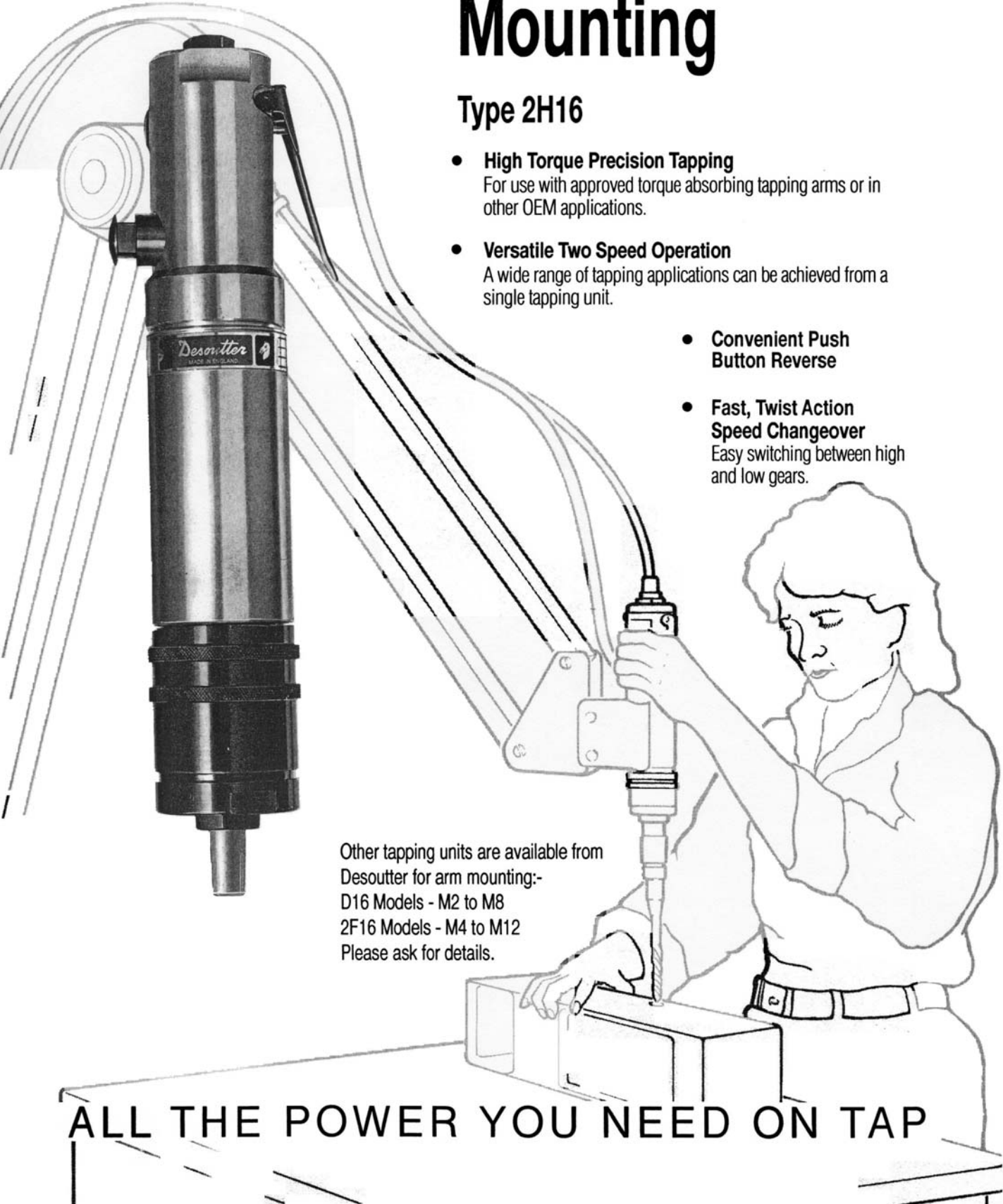

# Air Tapping Units for Machine Arm Mounting

## Type 2H16

- **High Torque Precision Tapping**  
For use with approved torque absorbing tapping arms or in other OEM applications.
- **Versatile Two Speed Operation**  
A wide range of tapping applications can be achieved from a single tapping unit.
- **Convenient Push Button Reverse**
- **Fast, Twist Action Speed Changeover**  
Easy switching between high and low gears.



Other tapping units are available from Desoutter for arm mounting:-  
D16 Models - M2 to M8  
2F16 Models - M4 to M12  
Please ask for details.

ALL THE POWER YOU NEED ON TAP

# 2H16 Air Tapping Unit

## Specification

Type	High Speed Setting r/min.	Low Speed Setting r/min.	Tapping Capacity	Available Torque		Output Spindle Taper (DIN)	Air Consumption l/s	Min. Hose Bore mm	Air 2) Inlet BSP	Sound 3) Level dB (A)	Ordering Code
				High Speed Nm	Low Speed Nm						
2H16-L-250/800	800	250	M4-M16	29	90	B18	15.6	12	3/8"	84	1434184
2H16-L-250/800	800	250		29	90	B16					1452444
2H16-L-160/500	500	160		47	140	B18					1434264
2H16-L-90/250	250	90		(subject to torque limitation)		B18					1434344

<sup>1)</sup> Tapping Figures are a guide only. Actual tapping test are always recommended.

<sup>3)</sup> When fitted with exhaust silencer.

<sup>2)</sup> 1/4" BSP air inlet adaptor supplied with unit. NPT air inlet optional.

Performance data obtained at a line pressure of 6 bar. Speeds indicated are nominal. Specifications are subject to change without prior warning.

## Accessories

A comprehensive range of Airline Equipment is available from Desoutter. Please ask for publication

### Lou Zampini & Associates

2 Douglas Pike, Rt. 7

Smithfield, RI 02917

1 800 353 4676

FAX 1 401 679 0165

Adaptor		
Fem. Thread Size BSP A	Male Thread Size BSP B	Part No.
1/2"	3/8"	62992

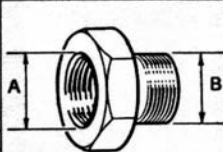
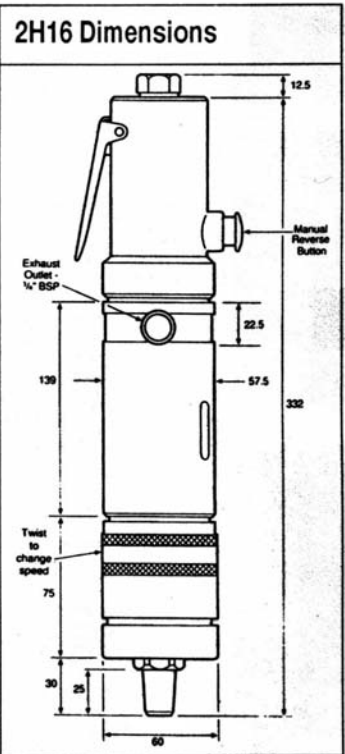
CE - Machinery to be Incorporated

For Further Information on Ergonomics and Workplace Design ask for Desoutter publication LT198

