

## AFD205/AFD215 pneumatic drive

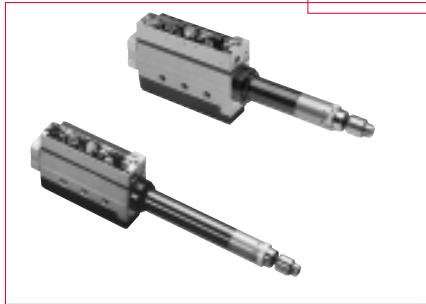

- Options of compact AFD205 or long stroke AFD215
- High thrust/size ratio
- Capacity up to 5mm (3/16") in aluminium
- Modular output spindles

### Lou Zampini & Associates

2 Douglas Pike, Rt. 7  
Smithfield, RI 02917

1 800 353 4676

FAX 1 401 679 0165

### AFD205

drilling performance specification

TOOL TYPE	SPEED		POWER		THRUST		STROKE		WEIGHT		AIR CONSUMPTION		SOUND LEVEL
	rpm		kW	HP	N	lbf	mm	ins	kg	lb	l/s <sup>2</sup>	cfm	dB(A)
model code	no load speed		motor power		dynamic thrust		working stroke		weight		continuous running		
AFD205-650	650		0.22	0.30	400	90	50	1.97	3.9	8.6	9.5	20	75
AFD205-1000	1000		0.22	0.30	400	90	50	1.97	3.9	8.6	9.5	20	75
AFD205-2700	2700		0.22	0.30	400	90	50	1.97	3.9	8.6	9.5	20	75
AFD205-4350	4350		0.22	0.30	400	90	50	1.97	3.9	8.6	9.5	20	75
AFD205-10000	10000		0.22	0.30	400	90	50	1.97	3.9	8.6	9.5	20	75
AFD205-18700	18700		0.22	0.30	400	90	50	1.97	3.9	8.6	9.5	20	75

### AFD215

drilling performance specification

TOOL TYPE	SPEED		POWER		THRUST		STROKE		WEIGHT		AIR CONSUMPTION		SOUND LEVEL
	rpm		kW	HP	N	lbf	mm	ins	kg	lb	l/s <sup>2</sup>	cfm	dB(A)
model code	no load speed		motor power		dynamic thrust		working stroke		weight		continuous running		
AFD215-650	650		0.22	0.30	400	90	90	3.54	4.2	9.2	9.5	20	75
AFD215-1000	1000		0.22	0.30	400	90	90	3.54	4.2	9.2	9.5	20	75
AFD215-2700	2700		0.22	0.30	400	90	90	3.54	4.2	9.2	9.5	20	75
AFD215-4350	4350		0.22	0.30	400	90	90	3.54	4.2	9.2	9.5	20	75
AFD215-10000	10000		0.22	0.30	400	90	90	3.54	4.2	9.2	9.5	20	75
AFD215-18700	18700		0.22	0.30	400	90	90	3.54	4.2	9.2	9.5	20	75

## AFD205/AFD215 accessories

ACCESSORIES RANGE	PAGE
Control Blocks	28
Output Spindles	30
Multiple Spindle Heads	34
Clamps	38

### AFD205/AFD215 pneumatic drive

AFD205 pneumatic drive

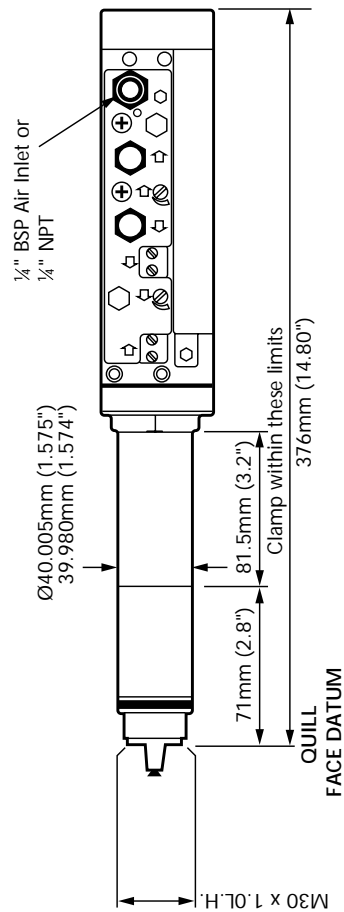
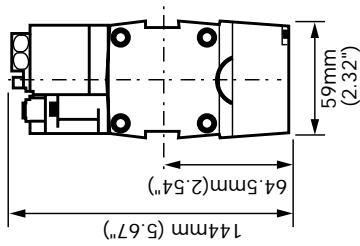

AFD215 pneumatic drive

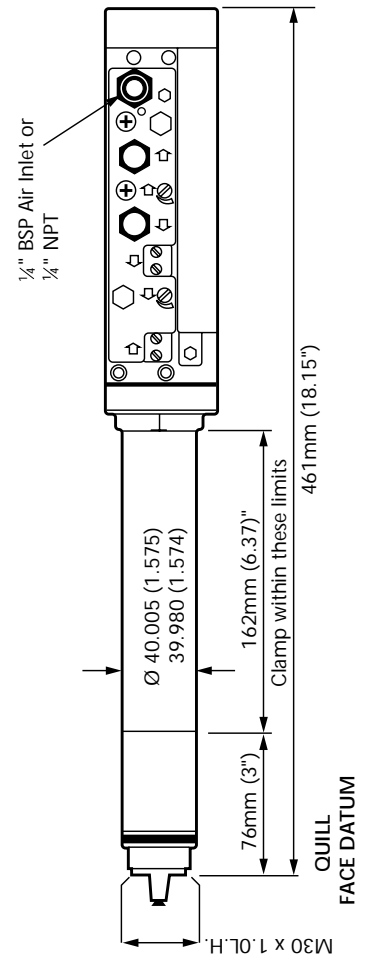
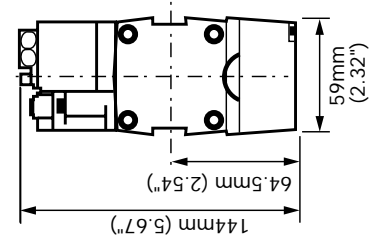

## AFD415 pneumatic drive



- Compact unit design
- Long working stroke of 100mm (3.94")
- Spindle sealed to IP64 standard
- Capacity up to 8mm (5/16") in mild steel, 10mm (3/8") in aluminium
- Modular output spindles

## AFD415

drilling performance specification

TOOL TYPE	SPEED		POWER		THRUST		STROKE		WEIGHT		AIR CONSUMPTION		SOUND LEVEL
	rpm		kW	HP	N	lbf	mm	ins	kg	lb	l/s <sup>2</sup>	cfm	dB(A)
model code	no load speed		motor power		dynamic thrust		working stroke		weight		continuous running		
AFD415-490	490		0.38	0.51	706	159	100	3.94	6.2	13.7	9.9	21	75
AFD415-790	790		0.38	0.51	706	159	100	3.94	6.2	13.7	9.9	21	75
AFD415-1250	1250		0.38	0.51	706	159	100	3.94	6.2	13.7	9.9	21	75
AFD415-2100	2100		0.38	0.51	706	159	100	3.94	6.2	13.7	9.9	21	75
AFD415-3400	3400		0.38	0.51	706	159	100	3.94	6.2	13.7	9.9	21	75
AFD415-5400	5400		0.38	0.51	706	159	100	3.94	6.2	13.7	9.9	21	75
AFD415-7000	7000		0.38	0.51	706	159	100	3.94	6.2	13.7	9.9	21	75
AFD415-18000	18000		0.38	0.51	706	159	100	3.94	6.2	13.7	9.9	21	75

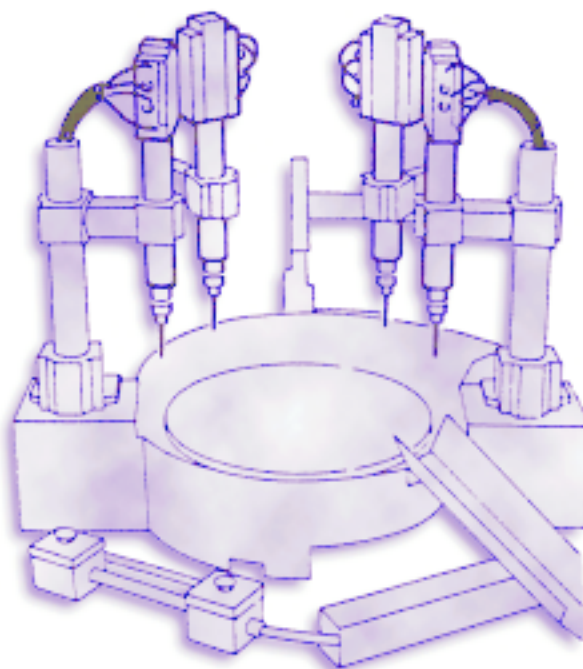

## AFD415 accessories

ACCESSORIES RANGE	PAGE
Control Blocks	28
Output Spindles	30
Multiple Spindle Heads	34
Clamps	39

AFD415 pneumatic drive

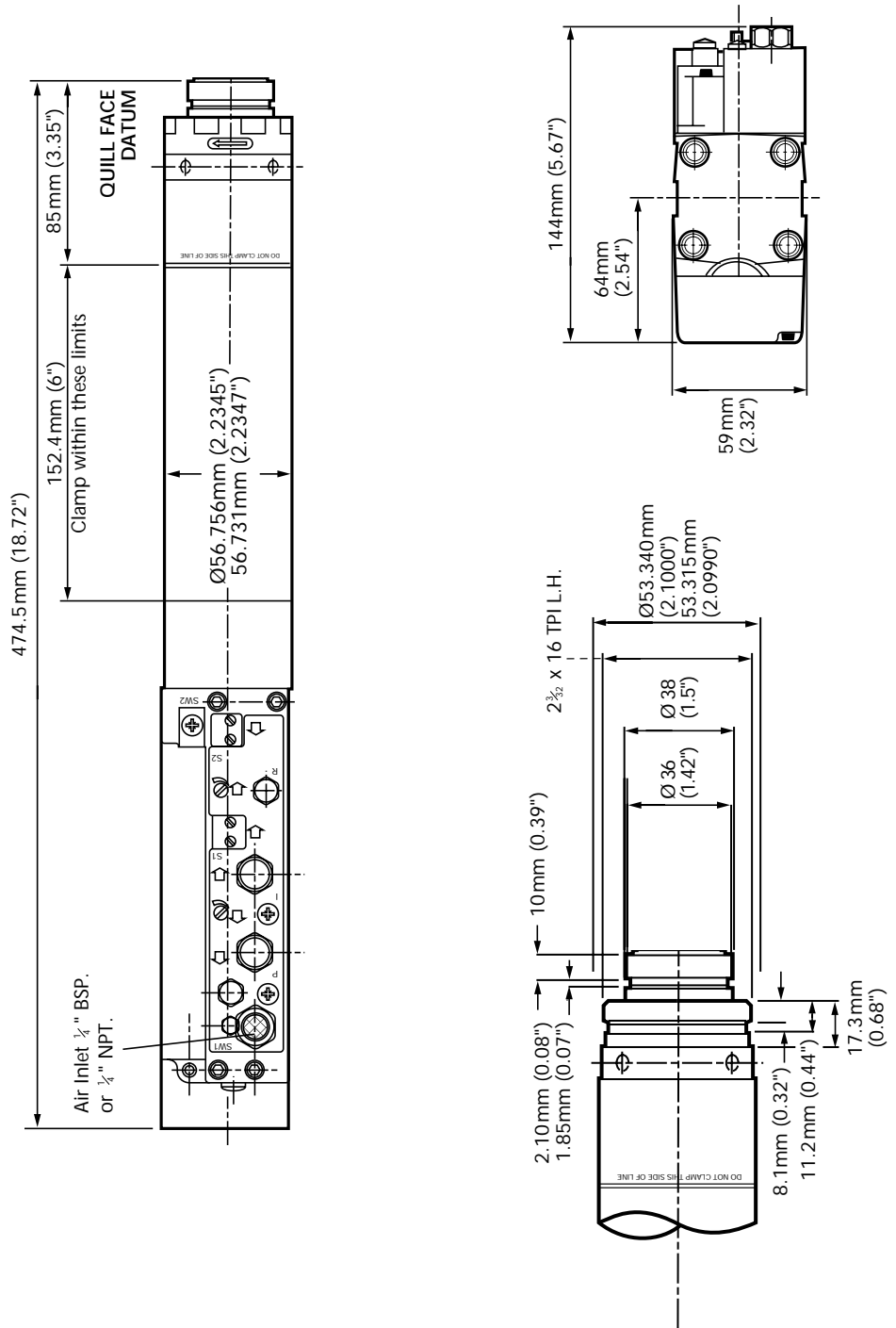

AFD60 pneumatic drive

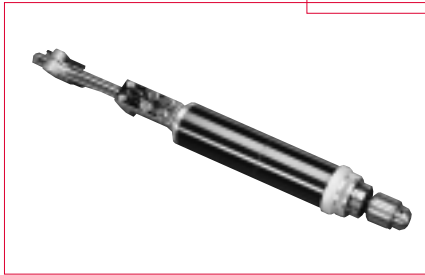

- Heavy duty pneumatic unit
- Chuck supplied fitted to tool, 10mm (3/8") for 1600-4300rpm and 13mm (1/2") for 550-1000rpm
- Full feature control block fitted as standard
- Capacity up to 16mm (5/8") in aluminium, 12mm (1/2") in mild steel

## AFD60

drilling performance specification

TOOL TYPE	SPEED		POWER		THRUST		STROKE		WEIGHT		AIR CONSUMPTION		SOUND LEVEL
	rpm		kW	HP	N	lbf	mm	ins	kg	lb	l/s <sup>2</sup>	cfm	dB(A)
model code	no load speed		motor power		dynamic thrust		working stroke		weight		continuous running		
AFD60-550	550		0.52	0.70	1200	269	95	3.74	8.1	17.8	15.6	33	77
AFD60-700	700		0.52	0.70	1200	269	95	3.74	8.1	17.8	15.6	33	77
AFD60-1000	1000		0.52	0.70	1200	269	95	3.74	8.1	17.8	15.6	33	77
AFD60-1600	1600		0.52	0.70	1200	269	95	3.74	8.1	17.8	15.6	33	77
AFD60-2100	2100		0.52	0.70	1200	269	95	3.74	8.1	17.8	15.6	33	77
AFD60-3000	3000		0.52	0.70	1200	269	95	3.74	8.1	17.8	15.6	33	77
AFD60-4300	4300		0.52	0.70	1200	269	95	3.74	8.1	17.8	15.6	33	77

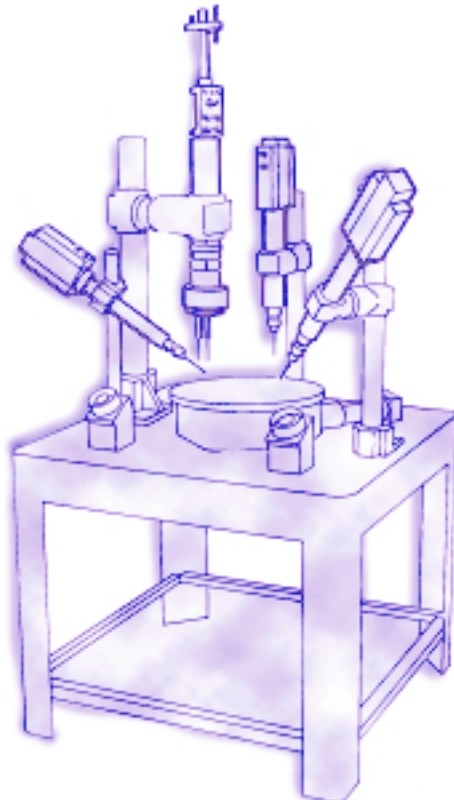

## AFD60 accessories

ACCESSORIES RANGE	PAGE
Control Options	29
Multiple Spindle Heads	34
Clamps	40

AFD60 pneumatic drive

