

## Retrofitting HCU's on older tools

There are several options available for retrofitting the new style HCU on older AFD's.

There are three mounting adaptor brackets as shown below. These are MADE TO ORDER items.

Part Number	X	For Tool Series
S21587	1 1/8"	AFD40
S21588	7/8"	AFD21
S21589	1.5"	AFD60/61*

\* Also requires cross-head change to S21492

## HCU Mounting Bracket

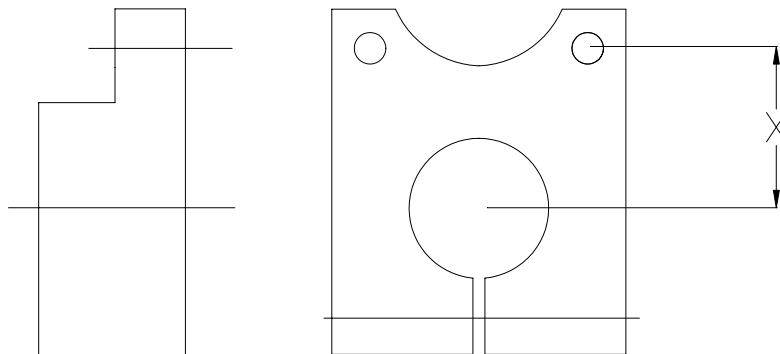

## How it works

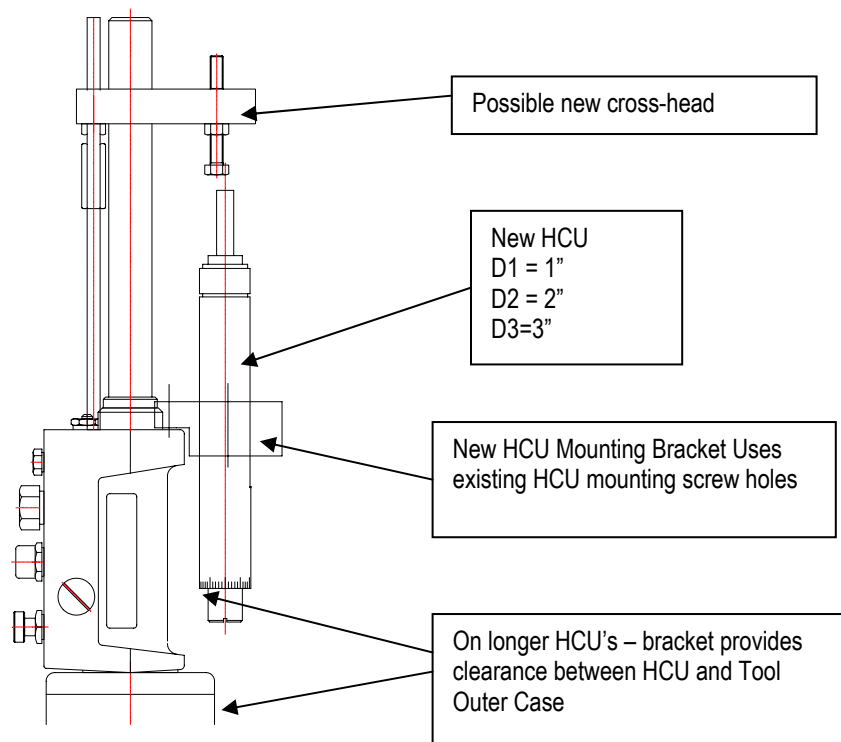
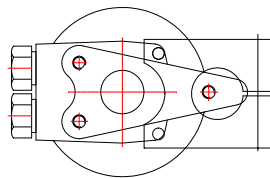

# Auto Feed Drills and Tappers HCU Mounting



North American Sales Company, 1800 Overview Drive, Rock Hill, SC 29730

Tel 803-817-7000

Fax 803-817-7257

D1-91942 1" HCU  
D2-91952 2" HCU  
D3-91962 3" HCU

A kit 94982 is also available for use with 40 and 60 series tools only – This will be stocked in small quantities – 10 and below

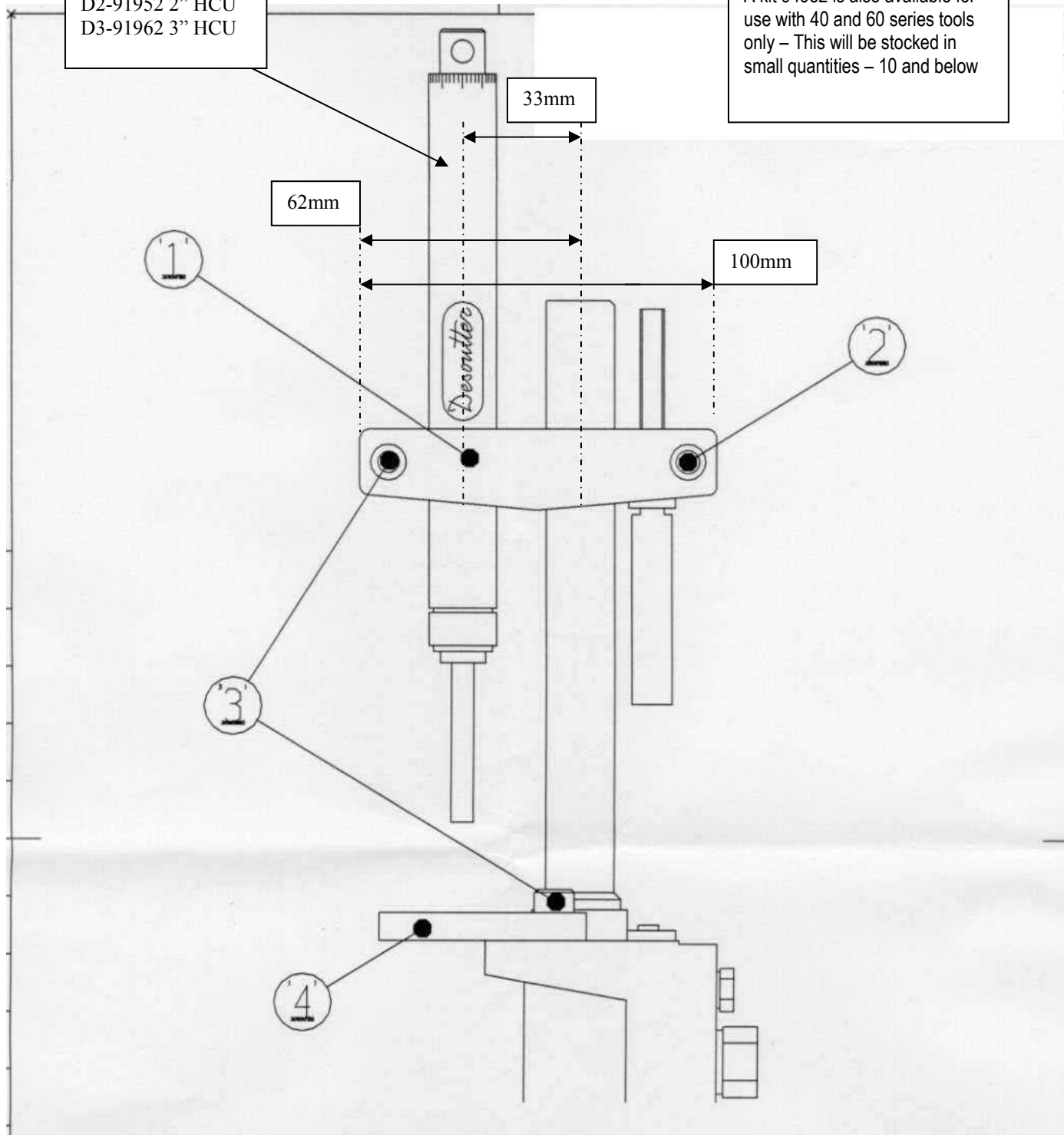

1	2070347363	1	CROSSHEAD (DESCHNER)
2	2050078283	1	SCREW SOCKET HEAD CAP
3	2050056063	3	SCREW SOCKET HEAD CAP
4	2070347353	1	STRIKER PLATE
ITEM No	PART No	No OFF	DESCRIPTION