

Desoutter



C Series

'Target-Tork' Screwdriver

Lou Zampini & Associates
37 Conifer Drive
North Providence, RI 02904
1 800 353 4676
FAX 401 679 0166
<http://www.desouttertools.com>

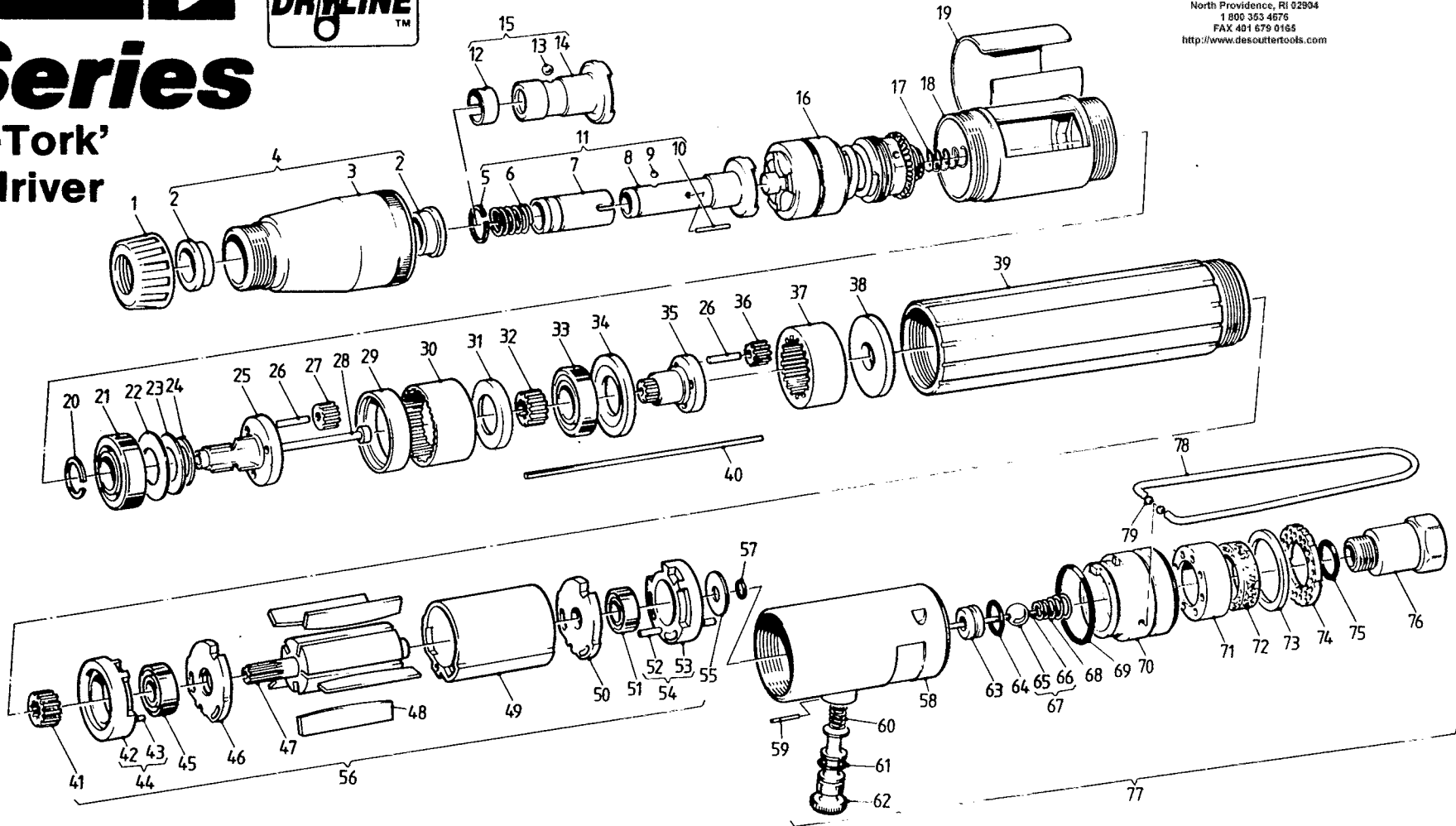

**Operating Instructions,
Servicing Instructions
and Parts List**

Type

- 2C89-AX-2000
- 2C89-AX-1450
- 2C89-AX-1000
- 2C89-AX- 500

Code

5/16" Drive

- 1354814
- 1354734
- 1354654
- 1354574

Code

1/4" Drive

- 1355704
- 1355624
- 1355544
- 1355464

REQUIREMENTS**Air Supply**

A water free and filtered air supply is required at a pressure of 6 bar (87 lbf/in²), with a flow of 6 l/s (12.7 cu.ft/min); controlled by a pressure regulator selected from the Desoutter Air Line Service Equipment Catalogue.

Lubrication

This is a DRYLINE tool designed to operate on a totally dry airline i.e., one without any oil or water moisture. The speed of the tool when operated dry will be found to be 10% lower than that stated on the tool nameplate; this will not alter the overall performance.

DRYLINE tools can also operate on a lubricated or partly lubricated airline thus allowing easy tool interchangeability with existing installations. If lubrication is required an airline lubricator should be fitted down stream of the filter.

Desoutter recommend the use of an ISO Viscosity Classified Oil, grade number ISO VG 15, in the lubricator.

Accessories

A wide range of screwdriving bits and nutrunning sockets are available and a suitable item should be selected from the Desoutter Accessories Catalogue.

The retention of these items is by spring loaded ball, which requires a sharp pull to release for the 5/16in bit holder, or by pulling the sleeve forward to release for the 1/4in bit holder.

OPERATING

Fit the required accessory into the tool and select the direction of rotation for tightening the fixing. Connect the air supply and holding the tool around the motor case, engage with the fixing and press down. The motor will start and tighten the fixing to the required torque, set by adjusting the tension on the clutch spring, at this point the internal drive is disengaged and the air to the motor cut off. To reset the tool remove from the fixing.

To engage reverse rotation depress reverse valve (62) and rotate to lock in position.

NOTE: With the same clutch setting a higher torque is always transmitted in reverse, ensuring removal of a set fixing.

- WARNING:**
- 1) Always disconnect tool from the power supply before attempting any replacement, adjustment, servicing or dismantling.
 - 2) Ensure that no loose articles of clothing or cleaning material can be caught by the rotating parts of the tool.
 - 3) Always allow the tool to stop before removing work or resting the tool.

- 4) Ensure that work piece is securely clamped before commencement of operation - clear all loose items from vicinity.

INITIAL SETTING

When received the torque output of the tool will require setting to match the job requirement.

It is recommended that a trial tightening operation is carried out to determine the amount of adjustment required. The ideal instrument for checking the torque is an electronic torque meter, request information from Desoutter; failing this a dial indicating torque wrench is adequate.

Clutch Adjustment

Rotate the spring ring (19) to uncover access hole in clutch case (18); insert clutch key, supplied with tool, and rotate to obtain the required torque.

SERVICING REQUIREMENTS**ATTENTION**

The rotor blades in this tool have a PTFE content. The normal Health and Safety recommendations concerning PTFE must be observed when handling these rotor blades.

- 1) Do not smoke.
- 2) Motor components must be washed with cleaning fluid and not blown clear with an air line.
- 3) The silencer must be replaced when dirty, do not clean and re-use.
- 4) Wash hands before commencing any other activity.

General Notes

Replace as necessary all 'O' rings, gaskets, bearings and rotor blades.

Use the following lubricants:

Oil - ISO Viscosity Classified - ISO VG 15, for motor.
Grease - BP FG00-EP, for motor bearings.
Grease - Duckhams Type Q5618, for gears and other bearings.
Silicone Grease - Molykote 33, for 'O' rings.

The following tools will be required:

Service Tool - Part No. 318793
Spanner - Part No. 29443, for Item (3).
Hexagon Key - Part No. 178883, for Item (18).

Any other tool will be found in a normal engineering workshop.

The following torque values MUST be used:

Item 1 to Item 4 : Hand Tighten.
Item 4 to Item 18 : 6.8Nm (5lbf.ft).
Item 18 to Item 39 : 27Nm (20lbf.ft).
Item 76 to Item 58 : 13.5Nm (10lbf.ft).

Items (66 & 76) have Right Hand threads, all other threads in the tool are Left Hand.

Replace as necessary all 'O' rings, bearings and rotor blades.

Bearings that have a retainer holding the balls in place must be assembled into the tool with the blank face of the retainer to the air flow; in the case of the motor the blank faces must face each other across the rotor.

Customers wishing to service the clutch (16) should request a separate service sheet from Desoutter.

From the front of the tool remove the bearing housing complete (4) and withdraw the bit holder (11 or 15), the clutch (16) and spring (17); then from the rear of the tool unscrew inlet adaptor (76) followed by spring (68), and valve stem complete (67), if possible withdraw push rod (40).

Clamp the service tool, part no. 318793, in a vice so that the tool can be loaded vertically into position. Using hexagon key, part no. 178883, unscrew clutch housing (18), remove from the service tool. The control top can now be unscrewed and the internal components withdrawn from the motor case.

The remainder of the dismantling follows normal engineering practice with reference to the illustration.

TO ASSEMBLE

NOTES: 1) Push rod adjustment is provided by repositioning ball (65) on push rod (66), see Final Adjustments for requirements. If a new ball and push rod are being used, the ball should be screwed fully onto the push rod before commencing adjustment.

- 2) Motor lubricating oil only required for assembly when not in use.

Sub-Assemblies

Using the illustration as a guide assemble the components into convenient sub-assemblies, including the clutch if dismantled.

The following instructions for the motor complete (56) must be followed.

Take the rotor (47) and place the rear bearing plate (50), with grooves to rotor, into position. Press bearing (51) onto the rotor so that there is a 0.038mm (0.0015in) gap between the rotor and the rear bearing plate. Holding the rotor and rear bearing plate assembly with the gear end of the rotor uppermost, slide the cylinder (49) over the rotor.

REQUIREMENTS**Air Supply**

A water free and filtered air supply is required at a pressure of 6 bar (87 lbf/in²), with a flow of 6 l/s (12.7 cu ft/min); controlled by a pressure regulator selected from the Desoutter Air Line Service Equipment Catalogue.

Lubrication

This is a DRYLINE tool designed to operate on a totally dry air line i.e. one without any oil or water moisture. The speed of the tool when operated dry will be found to be 10% lower than that stated on the tool nameplate; this will not alter the overall performance.

DRYLINE tools can also operate on a lubricated or partly lubricated air line thus allowing easy tool interchangeability with existing installations. If lubrication is required an air line lubricator should be fitted down stream of the filter.

Desoutter recommend the use of an ISO Viscosity Classified Oil, grade number ISO VG 15, in the lubricator.

Accessories

A wide range of screwdriving bits and nutrunning sockets are available and a suitable item should be selected from the Desoutter Accessories Catalogue.

The retention of these items is by spring loaded ball, which requires a sharp pull to release for the 5/16in bit holder, or by pulling the sleeve forward to release for the 1/4in bit holder.

OPERATING

Fit the required accessory into the tool and select the direction of rotation for tightening the fixing. Connect the air supply and holding the tool around the motor case, engage with the fixing and press down. The motor will start and tighten the fixing to the required torque, set by adjusting the tension on the clutch spring, at this point the internal drive is disengaged and the air to the motor cut off. To reset the tool remove from the fixing.

To engage reverse rotation depress reverse valve (62) and rotate to lock in position.

NOTE: With the same clutch setting a higher torque is always transmitted in reverse, ensuring removal of a set fixing.

WARNING: 1) Always disconnect tool from the power supply before attempting any replacement, adjustment, servicing or dismantling.

2) Ensure that no loose articles of clothing or cleaning material can be caught by the rotating parts of the tool.

3) Always allow the tool to stop before removing work or resting the tool.

4) Ensure that work piece is securely clamped before commencement of operation - clear all loose items from vicinity.

INITIAL SETTING

When received the torque output of the tool will require setting to match the job requirement.

It is recommended that a trial tightening operation is carried out to determine the amount of adjustment required. The ideal instrument for checking the torque is an electronic torque meter, request information from Desoutter; failing this a dial indicating torque wrench is adequate.

Clutch Adjustment

Rotate the spring ring (19) to uncover access hole in clutch case (18); insert clutch key, supplied with tool, and rotate to obtain the required torque.

SERVICING REQUIREMENTS**ATTENTION**

The rotor blades in this tool have a PTFE content. The normal Health and Safety recommendations concerning PTFE must be observed when handling these rotor blades.

- 1) Do not smoke.
- 2) Motor components must be washed with cleaning fluid and not blown clear with an air line.
- 3) The silencer must be replaced when dirty, do not clean and re-use.
- 4) Wash hands before commencing any other activity.

General Notes

Replace as necessary all 'O' rings, gaskets, bearings and rotor blades.

Use the following lubricants:

Oil - ISO Viscosity Classified - ISO VG 15, for motor.
Grease - BP FG00-EP, for motor bearings.
Grease - Duckhams Type Q5618, for gears and other bearings.
Silicone Grease - Molykote 33, for 'O' rings.

The following tools will be required:

Service Tool - Part No 318793
Spanner - Part No. 29443, for Item (3).
Hexagon Key - Part No. 178883, for Item (18).

Any other tool will be found in a normal engineering workshop.

The following torque values MUST be used:

Item 1 to Item 4 : Hand Tighten.
Item 4 to Item 18 : 6.8Nm (5lbf.ft).
Item 18 to Item 39 : 27Nm (20lbf.ft).
Item 76 to Item 58 : 13.5Nm (10lbf.ft).

Items (66 & 76) have Right Hand threads, all other threads in the tool are Left Hand.

Replace as necessary all 'O' rings, bearings and rotor blades

Bearings that have a retainer holding the balls in place must be assembled into the tool with the blank face of the retainer to the air flow; in the case of the motor the blank faces must face each other across the rotor.

Customers wishing to service the clutch (16) should request a separate service sheet from Desoutter.

From the front of the tool remove the bearing housing complete (4) and withdraw the bit holder (11 or 15), the clutch (16) and spring (17); then from the rear of the tool unscrew inlet adaptor (76) followed by spring (68), and valve stem complete (67), if possible withdraw push rod (40).

Clamp the service tool, part no. 318793, in a vice so that the tool can be loaded vertically into position. Using hexagon key, part no. 178883, unscrew clutch housing (18), remove from the service tool. The control top can now be unscrewed and the internal components withdrawn from the motor case.

The remainder of the dismantling follows normal engineering practice with reference to the illustration.

TO ASSEMBLE

NOTES: 1) Push rod adjustment is provided by repositioning ball (65) on push rod (66), see Final Adjustments for requirements. If a new ball and push rod are being used, the ball should be screwed fully onto the push rod before commencing adjustment.

2) Motor lubricating oil only required for assembly when not in use.

Sub-Assemblies

Using the illustration as a guide assemble the components into convenient sub-assemblies, including the clutch if dismantled.

The following instructions for the motor complete (56) must be followed.

Take the rotor (47) and place the rear bearing plate (50), with grooves to rotor, into position. Press bearing (51) onto the rotor so that there is a 0.038mm (0.0015in) gap between the rotor and the rear bearing plate. Holding the rotor and rear bearing plate assembly with the gear end of the rotor uppermost, slide the cylinder (49) over the rotor. [2]

Locate the rotor blades (48) and lubricate, place the front bearing plate (46) in position, with grooves to rotor. Place this sub-assembly, gear end of rotor uppermost, onto a fixture which locates only on the rotor rear spigot. Align the location slots in both bearing plates with the pin holes in the cylinder and push on bearing (45). Press home until the bearing bottoms on the front bearing plate BUT do not preload the bearing. Locate the rear bearing housing, with its spring pin, onto the motor then press on the front bearing housing making sure that the spring pins are correctly located. Check for free rotation of the rotor.

Final Assembly

NOTE: Push rod (28) must be entered through final planet carrier (25) before the final gear unit is assembled in the tool.

Slide the motor complete (56) into the motor case (39) and as each gear unit is added allow the components to enter fully into the motor case. With the final gear unit in place push the motor complete partly out of the rear of the motor case so that pin (52) can be located in the control top, hand tighten the motor case fully into the control top.

Load the part-assembled tool onto the service tool, fit and tighten the clutch housing (18), then check that the drive is free to rotate.

Replace the clutch and bit holder units and retain with bearing housing complete.

Into the rear of the tool enter push rod (40), valve stem complete (67), spring (68) and the silencing components all retained by inlet adaptor (76).

The tool can now be connected to the air supply and tested for correct operation.

Final Adjustments

Requirement: 1) The drive **MUST NOT** rotate when the tool is at rest. If it does the push rod extension is too **LONG**.

2) The motor **MUST** develop maximum power. If it does not the push rod extension is too **SHORT**.

To achieve both requirements the ball should be positioned on the push rod so that the motor starts after 1.0 - 1.5mm (0.040 - 0.060in.) of axial movement in the drive has been taken up.

Customer Notes;

Item No.	Part No.	Description	Qty.	Item No.	Part No.	Description	Qty.
1	177163	Thread Protecting Cap	1	42	285523	Front Bearing Housing	1
2	73798	Bearing Bush	2	43	259953	Pin	1
3	314143	Bearing Housing	1	44	285593	Front Bearing Housing Complete	1
4	314133	Bearing Housing Complete	1	*45	33433	Bearing	1
*5	200083	Circlip	1	46	285543	Front Bearing Plate	1
6	301013	Spring	1	47	285463	Rotor - 2000rpm	1
7	301003	Sleeve	1	-	285453	Rotor - 1450rpm	1
8	300993	Bit Holder	1	-	285323	Rotor - 1000 & 500rpm	1
9	280313	Ball	2	*48	307513	Rotor Blade	5
10	251693	Spring Pin	1	49	285503	Cylinder	1
11	301033	Bit Holder Complete 1/4in Hex.	1	50	285533	Rear Bearing Plate	1
12	86058	Spring Ring	1	*51	8843	Bearing	1
13	72408	Ball	1	52	285563	Pin	1
14	301153	Bit Holder	1	53	285513	Rear Bearing housing	1
15	301143	Bit Holder Complete 5/16in Hex.	1	54	289683	Rear Bearing Housing Complete	1
16	301323	Clutch Assembly - White Spring	1	55	285483	End Cap	1
-	301293	Clutch Assembly - Black Spring	1	56	294353	Motor Complete - 2000rpm	1
-	304873	Clutch Assembly - Natural Spring	1	-	294373	Motor Complete - 1450rpm	1
17	252563	Spring	1	-	294363	Motor Complete - 1000 & 500rpm	1
18	314363	Clutch Housing	1	*57	221973	'O' Ring	1
19	302783	Spring Clip	1	58	314173	Control Top	1
*20	200083	Circlip	1	*59	74523	Spring Pin	1
*21	178543	Bearing	1	60	314183	Spring	1
22	216493	Shim	1	61	314203	'O' Ring	1
23	206633	Shim	1	62	314193	Reverse Valve	1
24	76640053	Shim	1	63	314213	Valve Seat	1
25	205193	Final Planet Carrier - 2000, 1450 & 1000rpm	1	*64	250913	'O' Ring	1
-	224513	Final Planet Carrier - 500rpm	1	65	314043	Ball	1
26	170233	Planet Pin	6	66	318533	Push Rod	1
27	170223	Planet Wheel - 2000, 1450 & 1000rpm	3	67	314223	Valve Stem Complete	1
-	224503	Planet Wheel - 500rpm	3	68	311103	Spring	1
# 28	205183	Push Rod	1	*69	173973	'O' Ring	1
39	216483	Shim Housing	1	70	314233	Silencer Housing	1
30	170273	Gear Ring	1	71	319723	Restrictor Ring	1
31	170253	Washer	1	72	316243	Silencer	1
32	170213	Pinion - 2000, 1450 & 1000rpm	1	73	316233	Spacer	1
*33	2423	Bearing	1	74	316223	Exhaust Ring	1
34	170243	Washer	1	*75	202323	'O' Ring	1
35	174313	Planet Carrier - 2000 & 1000rpm	1	76	314263	Inlet Adaptor - 1/4in BSP	1
-	174243	Planet Carrier - 1450rpm	1	-	314273	Inlet Adaptor - 1/4in NPT	1
-	312913	Planet Carrier - 500rpm	1	77	314153	Control Top Complete - 1/4in BSP	1
36	170223	Planet Wheel - 2000rpm	3	-	314163	Control Top Complete - 1/4in NPT	1
-	170763	Planet Wheel - 1450rpm	3	78	39433	Suspension Bail	1
-	224503	Planet Wheel - 1000 & 500rpm	3	79	4023	Ball - For Suspension Bail	2
37	174303	Gear Ring - 2000, 1000 & 500rpm	1	-	29932	Clutch Key	1
-	174253	Gear Ring - 1450rpm	1	-	222453	Exhaust Hose	1
38	307603	Bearing Plate	1	-	235203	Clip - Exhaust Hose	1
39	314443	Motor Case	1	-	179133	Clutch Spring - Black - 2000, 1000 & 500rpm	1
40	69783	Push Rod	1	-	179923	Clutch Spring - White - 1450, 1000 & 500rpm	1
41	170213	Pinion - 2000rpm	1	-			

* Indicates normal replacement items. It is recommended that adequate stocks are held for servicing requirements.

Indicates updated parts.

Always quote tool number, serial number and spare part number when ordering spares.



Desoutter Limited.
 319, Edgware Road, Colindale, London NW9 6ND
 Telephone: 081 205 7050 Telex: 21392
 Fax: 081 205 5167

Printed in England

8.92

[4]

Locate the rotor blades (48) and lubricate, place the front bearing plate (46) in position, with grooves to rotor. Place this sub-assembly, gear end of rotor uppermost, onto a fixture which locates only on the rotor rear spigot. Align the location slots in both bearing plates with the pin holes in the cylinder and push on bearing (45). Press home until the bearing bottoms on the front bearing plate BUT do not preload the bearing. Locate the rear bearing housing, with its spring pin, onto the motor then press on the front bearing housing making sure that the spring pins are correctly located. Check for free rotation of the rotor.

Final Assembly

NOTE: Push rod (28) must be entered through final planet carrier (25) before the final gear unit is assembled in the tool.

Slide the motor complete (56) into the motor case (39) and as each gear unit is added allow the components to enter fully into the motor case. With the final gear unit in place push the motor complete partly out of the rear of the motor case so that pin (52) can be located in the control top, hand tighten the motor case fully into the control top.

Load the part-assembled tool onto the service tool, fit and tighten the clutch housing (18), then check that the drive is free to rotate.

Replace the clutch and bit holder units and retain with bearing housing complete.

Into the rear of the tool enter push rod (40), valve stem complete (67), spring (68) and the silencing components all retained by inlet adaptor (76).

The tool can now be connected to the air supply and tested for correct operation.

Final Adjustments

Requirement: 1) The drive MUST NOT rotate when the tool is at rest. If it does the push rod extension is too LONG.

2) The motor MUST develop maximum power. If it does not the push rod extension is too SHORT.

To achieve both requirements the ball should be positioned on the push rod so that the motor starts after 1.0 - 1.5mm (0.040 - 0.060in.) of axial movement in the drive has been taken up.

Customer Notes;