

Desoutter D Series

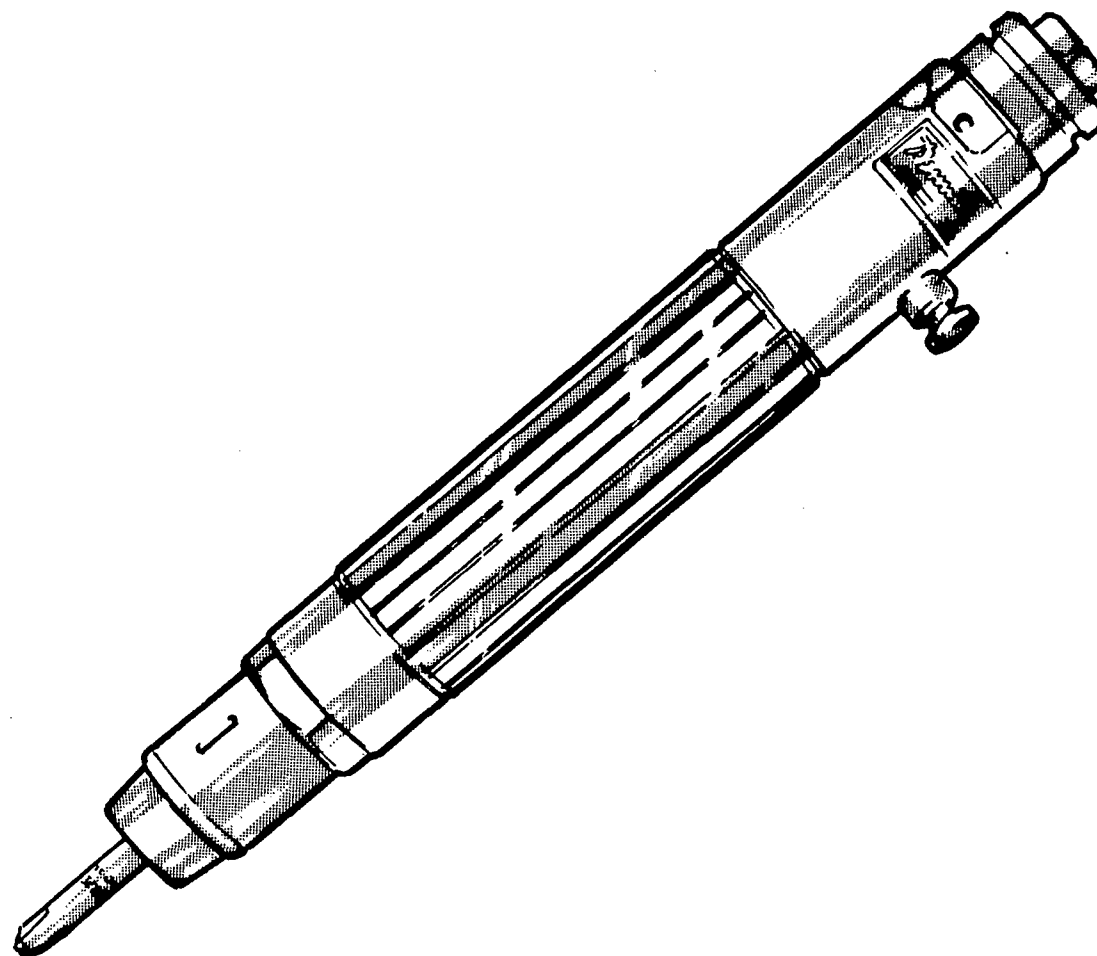

**Screwdrivers & Nutrunners;
Push Start and Reversible**

Types	Code	Code
	5/16in Drive	1/4in Drive
2D8-AX-2200	1260844	1257614
2D8-AX-1500	1269954	1270064
2D8-AX-1000	1260924	1257794
2D8-AX-600	1270144	1270224



**Operating Instructions
Servicing Instructions
Parts List**



Desoutter Limited,
319 Edgware Road, Colindale, London NW9 6ND.
Telephone: 01-205 7050 Telex: 21392

2D8-AX

Main Assembly

2D8-AX

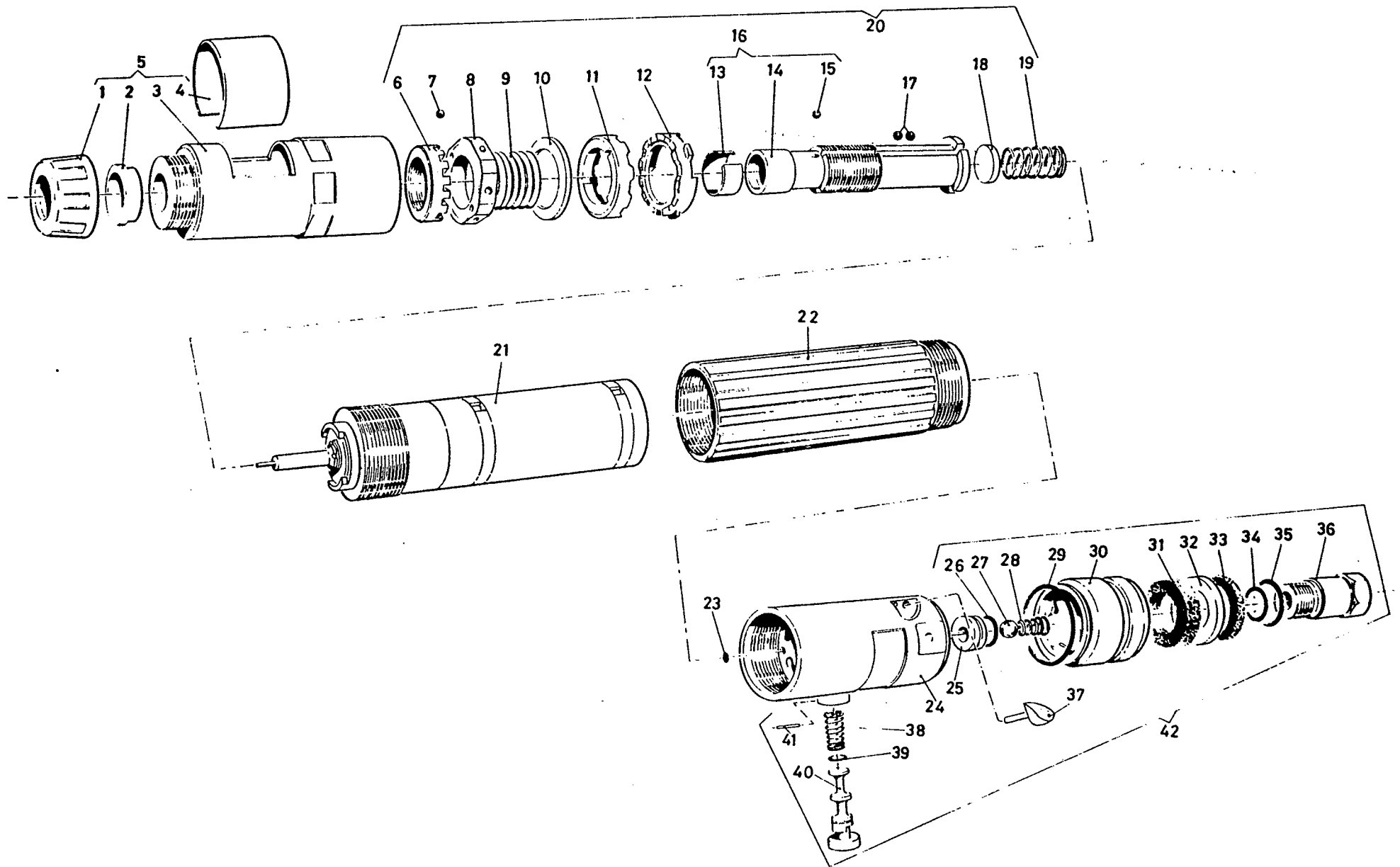

2D8-AX

Parts List - Main Assembly

2D8-AX

Item No.	Part No.	Description	Qty.	Item No.	Part No.	Description	Qty.
1	74088	Thread Protecting Cap	1	*23	221973	'O' Ring	1
2	73798	Bearing Bush	1	24	261483	Control Top	1
3	251533	Clutch Case	1	25	252383	Valve Seat	1
4	76713	Spring Ring	1	*26	500953	'O' Ring	1
5	251543	Clutch Case Complete	1	27	273843	Push rod and Ball Assembly	1
6	76003	Adjusting Nut	1	28	252493	Spring	1
7	72228	Ball	3	*29	203423	'O' Ring	1
8	76013	Locking Washer	1	30	252423	Silencer Housing	1
9	71378	Clutch Spring - Yellow	1	31	252933	Felt Silencer	1
-	67428	Clutch Spring - Red	1	32	252483	Spacer	1
-	68448	Clutch Spring - Green	1	33	252453	Sintered Silencer	1
10	67148	Retaining Washer	1	*34	202313	'O' Ring	1
11	67138	Sliding Clutch	1	*35	268513	'O' Ring	1
12	76683	Fixed Clutch	1	36	261503	Inlet Adaptor - 1/4in. BSP	1
13	86053	Spring Ring-1/4in.Hex. Drive	1	-	261513	Inlet Adaptor - 1/4in NPT	1
-	67458	Spring Ring-5/16in. Hex.Drive	1	37	252983	Insert	2
14	76723	Clutch Spindle-1/4in.Hex. Drive	1	38	252563	Spring	1
-	76703	Clutch Spindle-5/16in.Hex.Drive	1	*39	250913	'O' Ring	1
15	66863	Ball - 1/4in. Hex. Drive	1	40	252543	Reversing Valve	1
-	72408	Ball - 5/16in. Hex. Drive	1	41	259953	Spring Pin	1
16	87163	Clutch Spindle Complete - 1/4in. Hex. Drive	1	42	261283	Control Top Complete - 1/4in. NPT	1
-	87153	Clutch Spindle Complete - 5/16in. Hex. Drive	1	-	261433	Control Top Complete - 1/4in. BSP	1
17	72408	Ball	6	-	261443	Control Top Complete - 1/4in. NPT	1
18	69853	Seating	1	<p style="text-align: center;">Supplied Accessories</p>			
19	67448	Spring	1				
20	295853	Clutch Complete - Yellow - 1/4in. Hex. Drive	1				
-	295813	Clutch Complete - Yellow - 5/16in. Hex. Drive	1				
-	295863	Clutch Complete - Red - 1/4in. Hex. Drive	1				
-	295823	Clutch Complete - Red - 5/16in. Hex. Drive	1				
-	154223	Clutch Key	1				
-	39433	Suspension Bail	1				
-	222453	Exhaust Hose	1				
-	235203	Clip - Exhaust Hose	1				
21	See later section	Motor and Gearbox	1	9	-	Clutch Spring - next in series to extend torque range of tool	1
22	252953	Motor Case - 2200rpm	1	<p>* Indicates normal replacement items. It is recommended that adequate stocks are held for servicing requirements.</p>			
-	252963	Motor Case - 1500rpm	1	<p>Always quote tool model number, serial number and spare part number when ordering spares.</p>			
-	252973	Motor case - 1000 & 600rpm	1				

Customer Notes

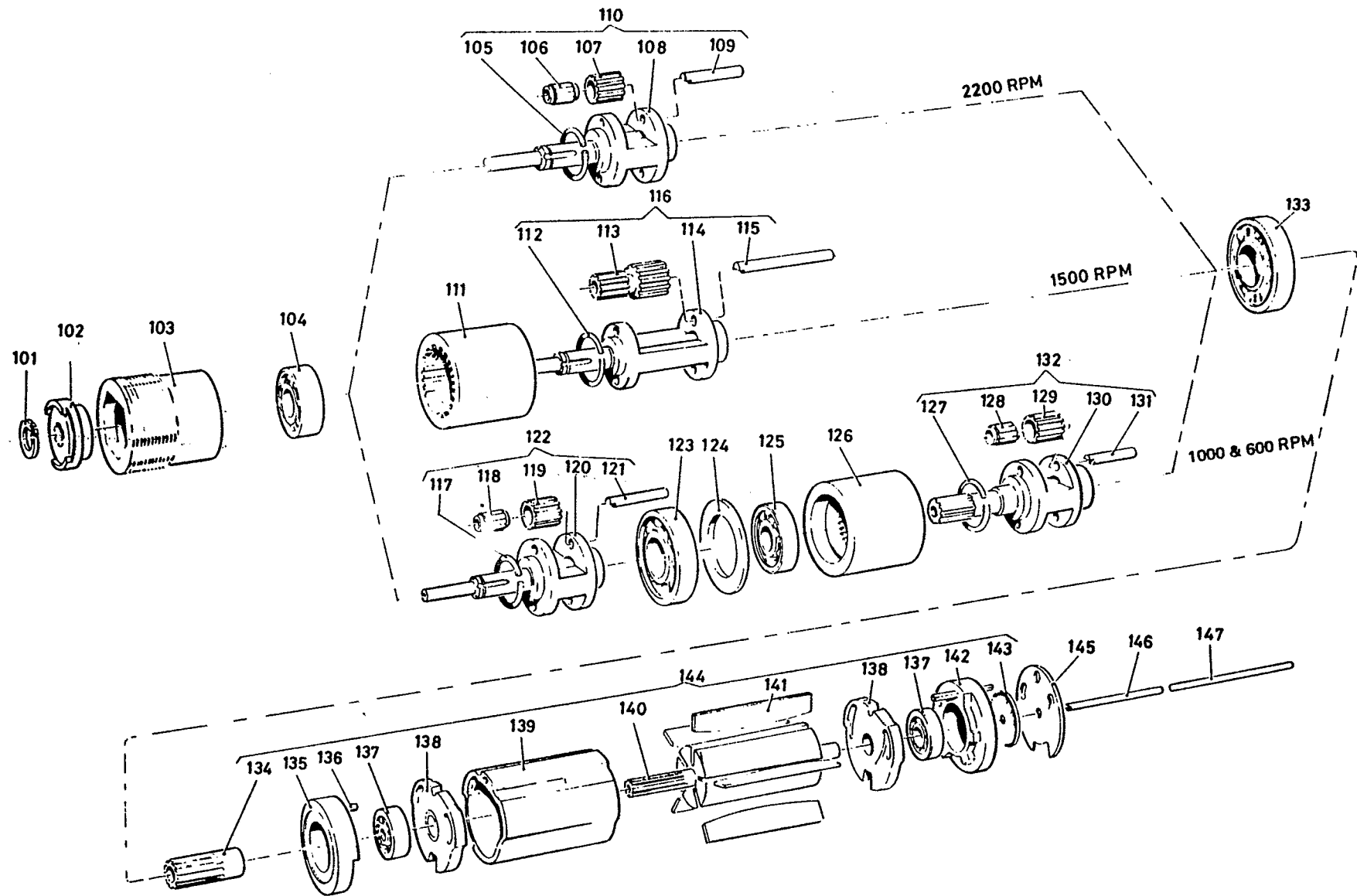

Item No.	Part No.	Description	Qty.	Item No.	Part No.	Description	Qty.	Item No.	Part No.	Description	Qty.
*101	42353	Circlip	1	120	69803	Planet Cage - 1000rpm	1	134	65373	Pinion - 800rpm	1
102	260023	Dog Clutch	1	-	69833	Planet Cage - 600	1	135	254893	Front Bearing Housing	1
103	269513	Gear and Nose- 2200rpm	1	121	80013	Planet Pin - 1000rpm	2	136	256123	Spring Pin	1
-	268973	Gear and Nose- 600 to 1000rpm	1	-	1453	Planet Pin - 600rpm	2	*137	33433	Bearing	2
-	252943	Bearing Housing- 1500rpm	1	122	69813	Planet Cage Complete -1000rpm	1	138	254873	Bearing Plate	2
*104	178543	Bearing	1	-	69823	Planet Cage Complete - 600rpm	1	139	254853	Cylinder	1
*105	25563	Circlip	1	*123	2413	Bearing	1	140	222033	Rotor - 2200rpm	1
*106	502093	Needle Bearing	2	124	37623	Washer	1	-	222043	Rotor - 1500rpm	1
107	150813	Planet Wheel	2	*125	2423	Bearing	1	-	237373	Rotor - 600rpm	1
108	268903	Planet Cage	1	126	36713	Gear Ring	1	*141	36613	Rotor Blade	5
109	1453	Planet Pin	2	*127	25573	Circlip - 1000 & 600rpm	1	142	254883	Rear Bearing Housing Complete	1
110	268893	Planet Cage Complete	1	*128	502093	Needle Bearing	2	143	270493	Cap	1
111	41703	Gear Ring	1	129	65383	Planet Wheel- 1000&600rpm	1	144	302633	Motor Complete- 2200rpm	1
*112	25563	Circlip	1	130	237313	Planet Cage - 1000rpm	1	-	302623	Motor Complete- 1500rpm	1
113	41683	Planet Wheel	2	131	1453	Planet Pin	2	-	302653	Motor Complete- 1000 & 600rpm	1
114	276753	Planet Cage	1	132	237323	Planet Cage Complete - 1000rpm	1	145	253003	Gasket	1
115	41693	Planet Pin	2	-	277483	Planet Cage - 600rpm	1	146	See Chart	Push rod	1
116	276763	Planet Cage Complete	1	133	2413	Bearing	1	147	See Chart	Push rod	1
*117	41623	Circlip - 1000rpm	1	-	277493	Planet Cage Complete - 600rpm	1				
-	37423	Circlip - 600 & 500rpm	1								
*118	502093	Needle Bearing - 600 & 500rpm	2								
119	42293	Planet Wheel - 1000rpm	2								
-	36703	Planet Wheel - 600 & 500rpm	2								

*Indicates normal replacement items. It is recommended that adequate stocks are held for servicing requirements.

Always quote tool model number, serial number and spare part number when ordering spares.

Customer Notes

Push Rod Chart

Push Rod	Used on RPM	Qty.	Size
222343 (146)	600 - 2200	1	42.5mm
278853 (147)	2200	1	71.5mm
278863 (147)	1500	1	84.0mm
278873 (147)	600 - 1000	1	104.0mm

REQUIREMENTS

Air Supply

A water free and filtered air supply is required at a pressure of 6 bar (87 lbf.in²), with a flow of 8.4 l/s (18 scfm); controlled by a pressure regulator selected from the Desoutter Air Line Service Equipment Catalogue.

Lubrication

This is a DRYLINE tool designed to operate on a totally dry airline i.e., one without any oil or water moisture. The speed of the tool when operated dry will be found to be 10% lower than that stated on the tool nameplate; this will not alter the overall performance.

DRYLINE tools can also operate on a lubricated or partly lubricated airline thus allowing easy tool interchangeability with existing installations. If lubrication is required an airline lubricator should be fitted down stream of the filter.

Desoutter recommend the use of an ISO Viscosity Classified Oil, grade number ISO VG 15, in the lubricator.

Accessories

A wide range of screwdriving bits and nutrunning sockets are available and a suitable item should be selected from the Desoutter Accessories Catalogue.

The retention of these items is by spring loaded ball, which requires a sharp pull to release for the 5/16 in bit holder, or by pulling the sleeve forward to release for the 1/4 in bit holder.

OPERATING

With the correct accessory fitted connect the tool to the air supply. Grip the tool around the motor case and press onto the fixing that is to be tightened. Depress the start lever. The motor will start and tighten the fixing to the required torque, set by adjusting the tension on the clutch spring, at this point the internal drive disengages and the air to the motor cut off.

To engage reverse rotation press the reverse button and rotate it to lock in position.

NOTE: With the same clutch setting a higher torque is always transmitted in reverse, ensuring a speedy fastener removal.

WARNING

- 1) Always disconnect tool from the power supply before attempting any replacement, adjustment, servicing or dismantling.
- 2) Ensure that no loose articles of clothing or cleaning material can be caught by the rotating parts of the tool.
- 3) Always allow the tool to stop before removing work or resting tool.
- 4) Ensure that work piece is securely clamped before commencement of operation — clear all loose items from vicinity.

INITIAL SETTING

When received the torque output of the tool will require setting to match the job requirement.

It is recommended that a trial tightening operation is carried out to determine the amount of adjustment required. The ideal instrument for checking the torque is an electronic peak meter (request information from Desoutter); failing this a dial indicating torque wrench is adequate.

Clutch Adjustment

Rotate spring clip to uncover access hole in clutch case, insert clutch key, supplied with tool, and rotate to obtain the required torque (see illustration).

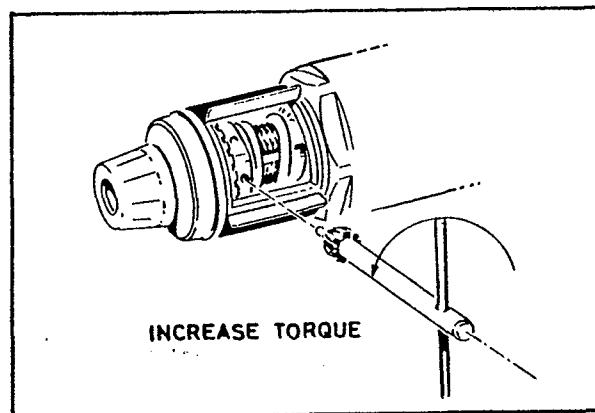

SERVICE REQUIREMENTS

General Notes

Use the following lubricants:

Grease - Duckhams Type Q5618, for gears and bearings.
Silicone Grease - Molykote 33, for 'O' rings.

The following tools will be required:

Clamp Block - Part No. 39373 (1 pair)
Hexagon Key - Part No. 277343
Spanner — 32mm
Spanner — 19mm
Circlip Pliers

The following torque values **MUST** be used:

Item 1 to Item 5:-	Hand tighten
Item 5 to Item 103:-	24.4Nm (18lbf.ft.)
Item 103 to Item 22:-	30Nm (22lbf.ft.)
Item 22 to Item 42:-	Hand tighten, faces abutting
Item 36 to Item 24:-	13.5Nm (10lbf.ft.)

Replace as necessary all 'O' rings, gaskets, bearings and rotor blades.

Bearings that have a retainer holding the balls in place must be assembled into the tool with the blank face of the retainer to the air flow; in the case of the motor the blank faces must face each other across the rotor.

The threads in this tool are left hand with the exception of the air inlet adaptor.

It is important that the gear and nose/front bearing housing (103) is slackened first, NEVER attempt to unscrew the control top when the above component is fully tightened.

With the clutch (20) removed from the tool it is possible for push rod (146) to slide out of the tool — TAKE CARE.

ATTENTION:

The rotor blades in this tool have a PTFE content. The normal Health and Safety recommendations concerning PTFE must be observed when handling these rotor blades.

1. Do not smoke.
2. Motor components must be washed with cleaning fluid and not blown clear with an air line.
3. Sintered silencers must be replaced when dirty, do not clean and re-use.
4. Wash hands before commencing any other activity.

TO DISMANTLE

Mount the motor case (22) between a pair of clamp blocks and clamp firmly in a vice. Unscrew the clutch case (5) and remove the clutch complete (20). Withdraw the push rods running through the motor and gearbox, inspect it for straightness and store for future assembly. Release circlip (101) and pull off dog clutch (102).

Using the hexagon key unscrew the gear and nose/front bearing housing (103) then unscrew the control top. Remove the tool from the clamp blocks and push the internal components out of the motor case.

The remainder of the dismantling follows normal engineering practice with reference to the illustration.

TO ASSEMBLE**Assembly Notes**

- 1) There is only one location hole in control top complete (42) that the pin must enter for correct assembly.

It is important that spacer (32) is located the correct way round concave side to the rear of the tool.

- 2) The push rod and ball assembly (27) is the point of adjustment for the run and stop actions of the tool. To check that the complete tool is correctly set; remove inlet adaptor (36) and spring (28). Hold the push rod and ball assembly (27) onto the valve seat (25) and check that there is 0.4 to 0.6mm (0.16 to 0.24in) of axial movement in the clutch complete (20) before the push rod and ball assembly is contacted. If incorrect reposition the ball on the push rod and recheck.

Sub Assemblies

Using the illustration as a guide, assemble control top, planet cages and if dismantled the clutch.

The following instructions for the motor complete (144) must be followed:-

Take the rotor (140) and place the rear bearing plate (138), with grooves to rotor, into position. Press bearing (137) onto the rotor so that there is a 0.038mm (0.015in.) gap between the rotor and the rear bearing plate. Holding the rotor and rear bearing plate assembly with the gear end of the rotor uppermost, slide the cylinder (139) over the rotor.

Locate the rotor blades (141) into their slots in the rotor and lubricate. Place the front bearing plate (138) into position, with grooves to rotor.

NOTE: If a new bearing (137) is to be fitted into the front bearing housing (135) make sure that the bearing is 0.25mm (0.010in.) below the housing face out of which pin (136) protrudes.

Press the front bearing housing with its bearing onto the rotor making sure that all location holes are aligned so that the pins can pass through on assembly.

NOTE: This assembly should be pressed on using the inner face of front bearing (137) and taking the reaction on the end face of the rotor rear bearing spigot. The assembly should be pressed on until all the free axial movement between the front and rear bearings is removed.

Locate the rear bearing housing (142) with cap (143) and check that the rotor is free to rotate.

Final Assembly

Stand control top on air inlet adaptor, locate 'O' ring (23) in its recess then place gasket (145) in position so that the required pin location hole is clear. Remove the rear bearing housing (142) from the motor complete (144) and locate in the control top, load the rest of the motor into position then slide the motor case (22) over the motor and screw fully into the control top. Slide the planet cage assemblies into the motor case checking that as each assembly is located the unit is free to rotate.

Mount the motor case (22) between a pair of clamp blocks and clamp firmly in a vice then using the hexagon key fully tighten the gear and nose/front bearing housing (103). Replace dog clutch (102) and retain with circlip (101). Slide the push rod into the tool then locate the clutch (20) making sure that seating (18) and spring (19) are in place. Screw the clutch case into position and release the tool from the clamps.

Check axial movement of the clutch as detailed in Assembly Notes 3 then connect the tool to the air supply and test for correct operation.