

Desoutter



Desoutter Limited. London NW9 6ND

2DM6

- (GB)** Servicing Instructions
Parts List
Operating Instructions
- (D)** Wartungsanleitung
Teilleiste
Bedienungsanleitung
- (F)** Manuel d'entretien
Liste de pièces
Manuel d'utilisation
- (E)** Instrucciones de Servicio
Listas de Repuestos
Instrucciones de Operación
- (P)** Instruções de Manutenção
Listas de Peças
Instruções de Funcionamento
- (I)** Istruzioni per la Manutenzione
Elenco delle Parti
Istruzioni Operative
- (GR)** Οδηγίες Συντήρησης
Κατάλογοι Ανταλλακτικών Μερών
Οδηγίες Λειτουργίας
- (NL)** Onderhoudsinstructies
Onderdelenlijst
Bedieningsinstructies
- (DK)** Servicevejledning
Liste over dele
Betjeningsvejledning
- (N)** Serviceinstruksjoner
Deleliste
Driftsinstruksjoner
- (S)** Serviceinstruktioner
Reservdelista
Bruksanvisning
- (FIN)** Huolto-ohjeet
Osaluettelo
Käyttöohjeet

2DM6-9000 1414584D

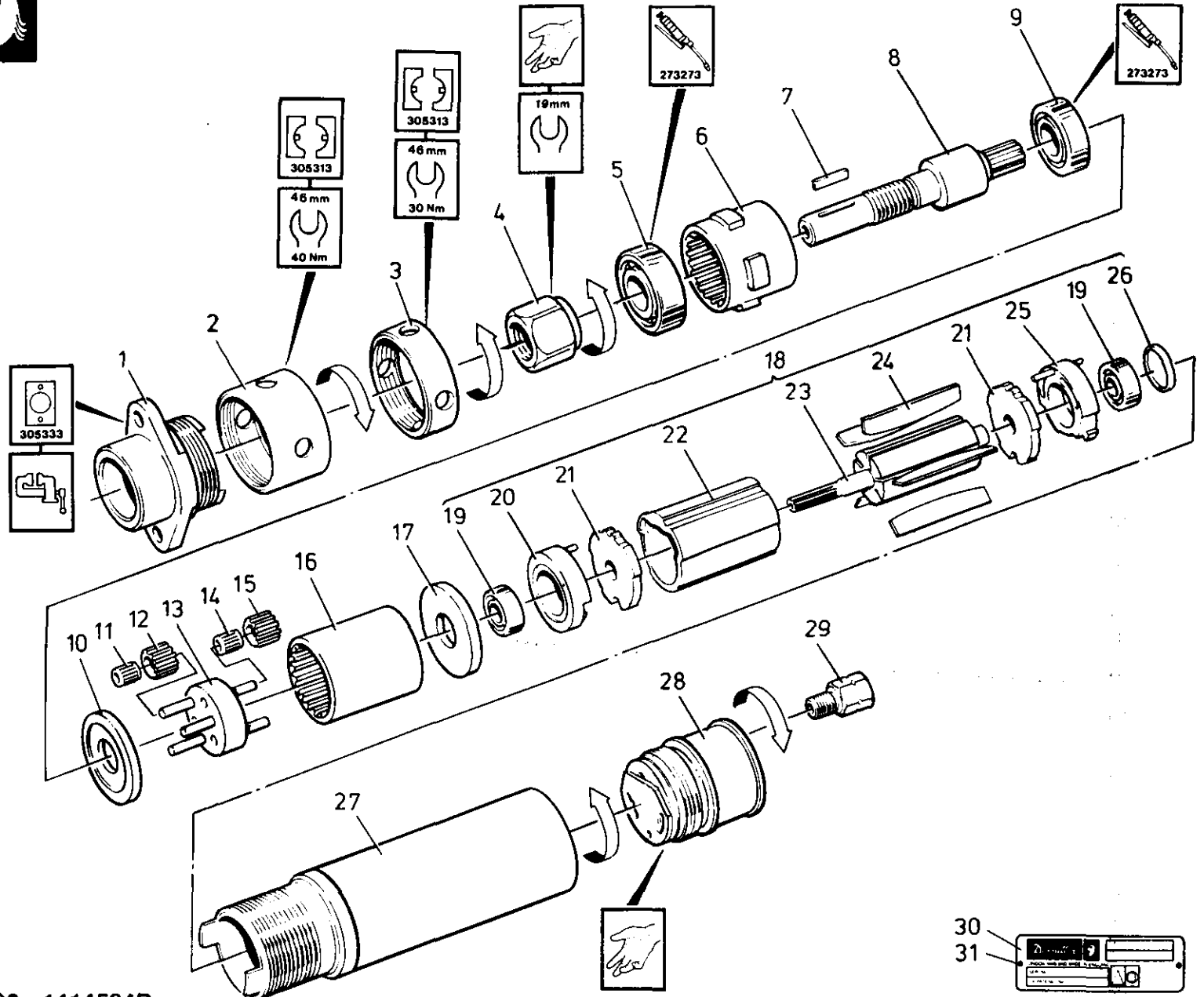

2DM6-9000 Parts List / Teileliste / Liste / Pièces

Item Ps. Nr. No. Article	Part No Teil Nr. Référence	Qty Menge Qté	Item Ps. Nr. No. Article	Part No Teil Nr. Référence	Qty Menge Qté
1	323083	1	22	254853	1
2	294993	1	23	266553	1
3	323073	1	*24	36613	5
4	323093	1	25	254883	1
*5	251983	1	26	254903	1
6	322863	1	27	323053	1
7	296863	1	28	298144	1
8	322943	1	29	61103	3
*9	323113	1		(1/8 NPT)	
*10	322873	1	30	355893	1
*11	298893	3	31	54853	2
12	299083	3			
13	293443	1			
*14	251663	3			
15	299113	3			
16	266483	1			
*17	306303	1			
18	268593	1			
*19	33433	2			
20	304673	1			
21	254873	2			

Service Kits

Service Ausrüstungen

Trousses d'Entretien

Part No Teil Nr. Référence	Item Ps. Nr. No. Article	Qty Menge Qté
356673	19	2
	24	5

- (GB) * Indicates normal replacement items. It is recommended that adequate stocks are held for servicing requirements. Always quote tool model number, serial number and spare part number when ordering spares.
- (D) * Bedeutet normale Verschleißteile. Es empfiehlt sich eine angemessene Menge für Wartungszwecke auf Lager zu halten. Bei der Bestellung von Ersatzteilen, bitte immer angeben: Typennummer der Bohrmaschine, Werknummer und Ersatzteilnummer.
- (F) * Le symbole astérisque (*) indique des articles de rechange normaux. Il est recommandé d'en conserver des stocks suffisants pour assurer toutes les opérations d'entretien courant. Lors de la commande de pièces de rechange, toujours citer le numéro de modèle de l'outillage, son numéro de série et le numéro de référence de chaque pièce de rechange.
- (E) * Indica elementos de reposición regular. Se recomienda tener una cantidad adecuada de los mismos en reserva a efectos de mantenimiento. Al encargar piezas de recambio, siempre debe indicarse el número de modelo de la herramienta, su número de serie y el número de la pieza de recambio.
- (P) * Indica itens que são substituídos regularmente. É recomendado que estoques adequados sejam mantidos para requisitos de manutenção. Cite sempre o número do modelo da ferramenta, número de série, e número da peça acessória quando pedindo acessórios.
- (I) * L'asterisco denota ricambi normali. Si consiglia di mantenere scorte adeguate alle esigenze della manutenzione. Nell'ordinazione di ricambi citare il numero di modello dell'utensile, il numero di matricola e quello di catalogo del pezzo.
- (GR) * Σημαίνει συνηθισμένα είδη (τεμάχια) για αντικατάσταση. Σας συνιστούμε να τηρείτε αρκετό απόθεμα από τα είδη που χρειάζονται αντικατάσταση. Όταν παραγγέλνετε ανταλλακτικά πάντα να γράφετε τον αριθμό μοντέλου του εργαλείου, τον αριθμό σειράς και τον αριθμό ανταλλακτικού.
- (NL) * Betekent normale reserveartikelen. Het verdient aanbeveling om voldoende voor onderhoudsbehoeften voorradig te hebben. Bij bestelling van reserveonderdelen geef altijd modelnummer, volgnummer en reserveonderdeelnnummer van het werktuig op.
- (DK) * Indikerer normale udskiftningsemner. Det anbefales at have rigelige forsyninger af dele til brug i forbindelse med eftersyn. Opgiv altid det korrekte værktøjsmodelnummer, serienummer og reservedelennummer ved bestilling af reservedele.
- (N) * Angir normale reservedeler. Det anbefales at tilstrekkelig antall reservedeler holdes på lager. Ved bestilling av deler må man alltid oppgi verktøyets modellnr., serienr. og reservedelens nr.
- (S) * Utmärker normala reservdelar. Vi rekommenderar att tillräckligt antal lagras för serviceändamål. Uppge alltid verktygets modellnummer, serienummer samt reservdelens nummer vid beställning av reservdelar.
- (FIN) * Viittaa tavallisiin varaosiin. Suosittelemme, että riittävä määrä pidetään varastossa huoltotarpeita varten. Työkalun mallinumero, sarjanumero ja varaosan numero on aina mainittava tilattaessa.



Desoutter Limited

STATEMENT OF USE

This motor is designed to be incorporated into a fixed or moving machine.
 It can be connected for either right or left rotation or switchable between the two with suitable valving.
 The motor should be mounted by the flange or threaded nose only.
 The risk of the motors being the source of ignition of a potentially explosive atmosphere is extremely small.
 The user is responsible for assessing the risks associated with the whole machine into which the motor is to be incorporated.

GENERAL

Recommended inlet hose

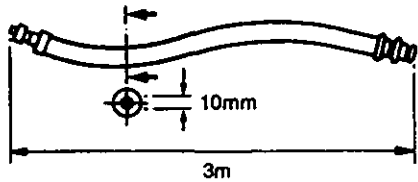

Lubrication

Correct lubrication is vital for the maximum performance of the tool and an airline lubricator should be fitted in the system down line of the filter. Use ISO VG 15.

- 158733 = Molycote PG75 273283 = BP FG00EP
- 208893 = Rocol M204G 27652 = ISO VG 15
- 273273 = BP Q5618

DATA

- Maximum air pressure Pmax = 6.3 bar
- Minimum air pressure Pmin = 2 bar
- Sound Pressure Level (dBa) = 73 re. CAGI-PNEUROP Test code
- Vibration Level (m/sec²) = <2.5 re. ISO 8662

Weight

Motor type/RPM	kg
2DM6-5, 45	0.88
2DM6-60, 90, 290	0.78
2DM6-390, 620, 980, 1650	0.78
2DM6-2700, 4200, 16000	0.60
2DM6-9000	0.80

ACCESSORIES

A range of accessories are available and suitable items should be selected from the Desoutter catalogue.

MAINTENANCE INSTRUCTIONS

1. Servicing should be carried out at intervals of 1000 hours' use.
2. All torque figures $\pm 10\%$.
3. Replace as necessary all 'O' rings, bearings and rotor blades, see service kit.
4. Indicates direction of dismantling.
5. When disposing of components, lubricants, etc, ensure that the relevant safety procedures are carried out.

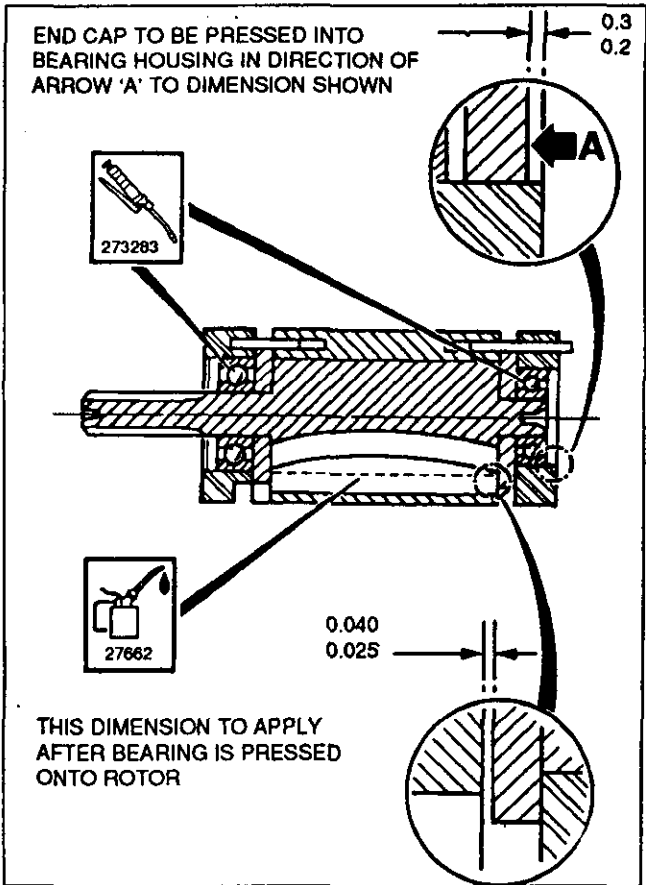

To Dismantle: refer to main illustration

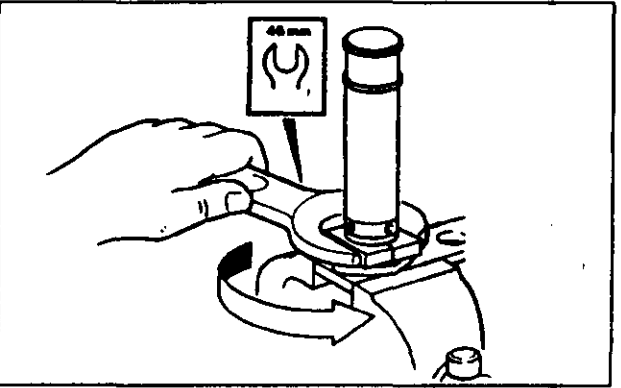
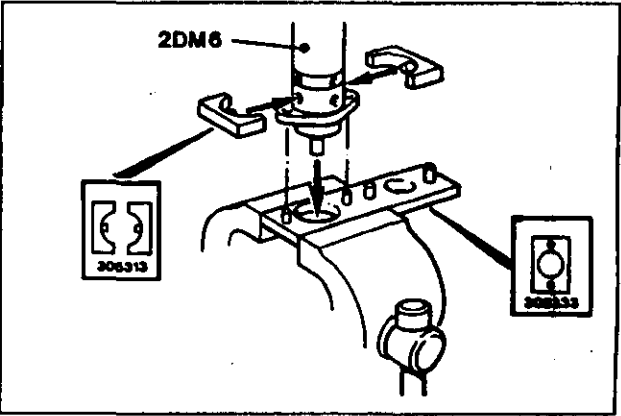

To Assemble: Motor complete, refer to main illustration

