

# Desoutter



Desoutter Limited. London NW9 6ND UK

## 2HM5

Service Instructions

**(GB)** Operating Instructions

Parts List

Wartungsanleitung

**(D)** Bedienungsanleitung

Teileliste

Manuel d'entretien

**(F)** Manuel d'utilisation

Liste de pièces

Instrucciones de Servicio

**(E)** Instrucciones de Operación

Listas de Repuestos

Instruções de Manutenção

**(P)** Instruções de

Funcionamento

Listas de Peças

Istruzioni per la

**(I)** Manutenzione

Istruzioni Operative

Elenco delle Parti

Οδηγίες Συντήρησης

**(GR)** Κατάλογοι Ανταλλακτικών Μερών

Οδηγίες Λειτουργίας

Onderhoudsinstructies

**(NL)** Bedieningsinstructies

Onderdelenlijst

Servicevejledning

**(DK)** Betjeningsvejledning

Liste over dele

Serviceinstruksjoner

**(N)** Driftsinstruksjoner

Delister

Serviceinstruktioner

**(S)** Bruksanvisning

Reservdelslista

Huolto-ohjeet

**(FIN)** Osaluettelo

Käyttöohjeet

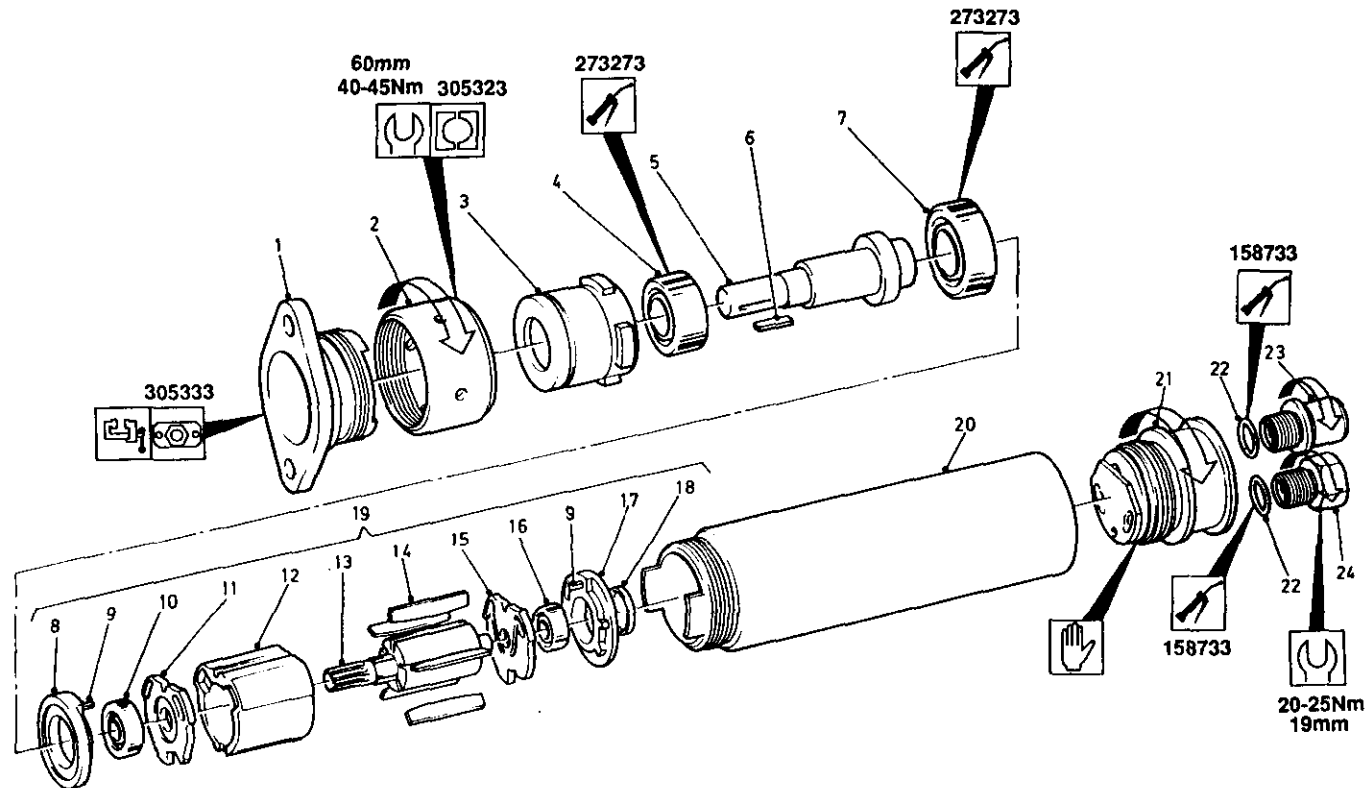

2HM5-18000 1309944 C

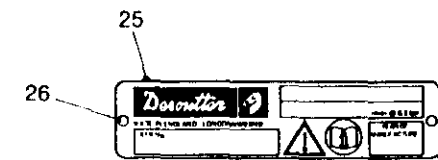

# Parts List/Teileliste/Liste de Pièces



Desoutter Limited. London NW9 6ND UK

Item No. Pos.Nr. No. Article	Part No. Teil. No. Référence	Qty Menge Qté	Item No. Pos.Nr. No. Article	Part No. Teil. No. Référence	Qty Menge Qté
1	295543	1	15	265053	1
2	277663	1	16	500693	1
3	290153	1	17	265063	1
* 4	290633	1	18	256773	1
5	295563	1	19	275783	1
6	290563	1	20	290553	1
* 7	1873	1	21	290003	1
8	285063	1	* 22	268513	2
9	258113	1	23	256433	1
* 10	80253	2	24	42953 (BSP)	1
11	285043	2	-	47133 (NPT)	1
12	285033	1	25	355893	1
13	285113	1	26	54853	2
* 14	9433	5			

\* Indicates normal replacement items. It is recommended that adequate stocks are held for servicing requirements.

Always quote tool model number, serial number and spare part number when ordering spares.

\* Bedeutet normale Verschleißteile. Es empfiehlt sich eine angemessene Menge für Wartungszwecke auf Lager zu halten.

Bei der Bestellung von Ersatzteilen, bitte immer angeben: Typennummer der Bohrmaschine, Werknummer und Ersatzteilnummer.

\* Le symbole astérisque (\*) indique des articles de rechange normaux. Il est recommandé d'en conserver de stocks suffisants pour assurer toutes les opérations d'entretien courant.

Lors de la commande de pièces de rechange, toujours citer le numéro de modèle de l'outillage, son numéro de série et le numéro de référence de chaque pièce de rechange.

\* Indica elementos de reposición regular. Se recomienda tener una cantidad adecuada de los mismos en reserva a efectos de mantenimiento.

Al encarga piezas de recambio, siempre debe indicarse el número de modelo de la herramienta, su número de serie y el número de la pieza de recambio.

\* Indica itens que são substituídos regularmente. É recomendado que estoques adequados sejam mantidos para requisitos de manutenção.

Cite sempre o número do modelo da ferramenta, número de série, e número da peça acessória quando pedindo acessórios.

\* L'asterisco denota ricambi normali. Si consiglia di mantenere scorte adeguate alle esigenze della manutenzione.

Nell'ordinazione di ricambi citari il numero di modello dell'utensile, il numero di matricola e quello di catalogo del pezzo.

\* Σημαίνει συνηθισμένα είδη (τεμάχια) για αντικατάσταση. Σας συνιστούμε να τηρείτε αρκετό απόθεμα από τα είδη που χρειάζονται αντικατάσταση.

Όταν παραγγέλνετε ανταλλακτικά πάντα να γράφτε τον αριθμό μοντέλου του εργαλείου, τον αριθμό σειράς και τον αριθμό ανταλλακτικού.

\* Betekent normale reserveatikelen. Het verdient aanbeveling om voldoende voor onderhoudsbehoeften voordig te hebben.

Bij Bestelling van reserveonderdelen geef altijd modelnummer, volgnummer en reserveonderdeelnnummer van het werktuig op.

\* Indikerer normale udskiftningsemner. Det anbefales at have rigelige forsyninger af dele til brug i forbindelse med eftersyn.

Opgiv altid det korrekte værktøjsmodelnummer, serienummer og reservedelsnummer ved bestilling af reservedele.

\* Angir normale reservedeler. Det anbefales at tilstrekkelig antall reservedeler holdes på lager.

Ved bestilling av deler må man alltid oppgi verktøyets modellnr., serienr. og reservedelens nr.

\* Utmärker normala reservdelar. Vi rekommenderar att tillräckligt antal lagras för serviceändamål.

Uppge alltid verktygets modellnummer, serienummer samt reservdelens nummer vid beställning av reservdelar.

\* Viittaa tavallisiin varaosiin. Suosittelemme, että riittäviä määriä pidetään varastossa huoltotarpeita varten.

Työkalun mallinnumero, sarjanumero ja varaosan numero on aina mainttava tilaattaessa.



Desoutter Limited. London NW9 6ND UK

**STATEMENT OF USE**

This motor is designed to be incorporated into a fixed or moving machine. It can be connected for either right or left rotation or switchable between the two with suitable valving.

The motor should be mounted by the flange or threaded nose only. The risk of the motors being the source of ignition of a potentially explosive atmosphere is extremely small.

The user is responsible for assessing the risks associated with the whole machine into which the motor is to be incorporated.

**GENERAL**

Recommended inlet hose

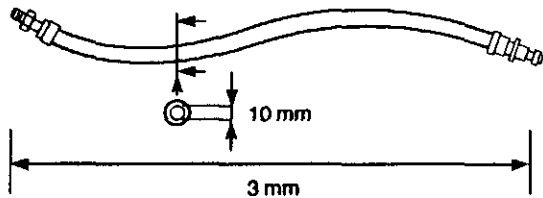

**LUBRICATION**

Correct lubrication is vital for the maximum performance of the tool and an airline lubricator should be fitted into the system down stream of the filter. Use ISO VG15.

158733 = Molykote PG75	273283 = BP FG00EP
208893 = Rocol M204G	27862(5L) = ISO VG15
273273 = BP Q5618	27852(250ml) = ISO VG15

**DATA**

Maximum air pressure Pmax	= 6.3 bar
Minimum air pressure Pmin	= 2 bar
Sound pressure level (dBA)	= 87 re.CAGI-PNEUROP Test code
Vibration level (m/s <sup>2</sup> )	= <2.5 re.ISO 8662

**WEIGHT**

Motor type/RPM	kg
2HM5-18000	1.4

**ACCESSORIES**

A range of accessories are available and suitable items should be selected from the Desoutter accessories catalogue.

**MAINTENANCE INSTRUCTIONS**

1. Servicing should be carried out at intervals of 1000 hours use.
2. All torque figures  $\pm 10\%$ .
3. Replace as necessary all 'O' rings, bearings and rotor blades, see service kits.



Indicates direction of dismantling.

5. When disposing of components, lubricants, etc. ensure that the relevant safety procedures are carried out.

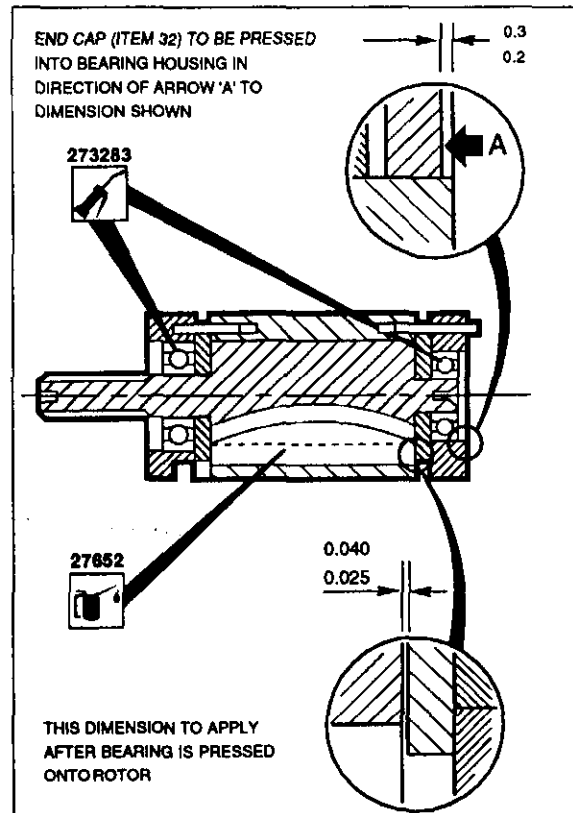

To Dismantle: Refer to main illustration

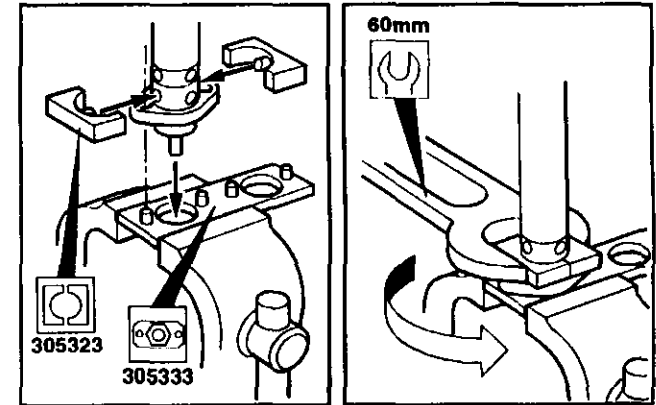

To Assemble: Motor complete, refer to main illustration

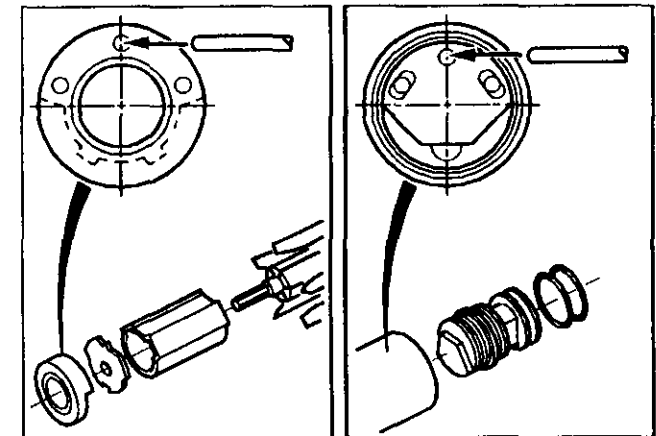

Copyright 1994, Desoutter, London NW9 6ND, UK

Any unauthorized use or copying of the contents or part thereof is prohibited. This applies in particular to trademarks, model denominations, part numbers and drawings.

Use only authorized parts. Any damage or malfunction caused by the used of unauthorized parts is not covered by Warranty or Product Liability.