

Desoutter



D Series

**Screwdrivers & Nutrunners;
Manual Start
& Non- Reversible**

Types	Code	Code
	5/16in Drive	1/4in Drive
D8-S-1700	1268144	1268224
D8-L-1700	1268564	1268644
D8-S-1100	1260264	1257874
D8-L-1100	1260344	1257954
D8-S- 700	1260424	1258004
D8-L- 700	1260504	1258184
D8-S- 500	1260684	1258264
D8-L- 500	1260764	1258344

**Operating Instructions
Servicing Instructions
Parts List**

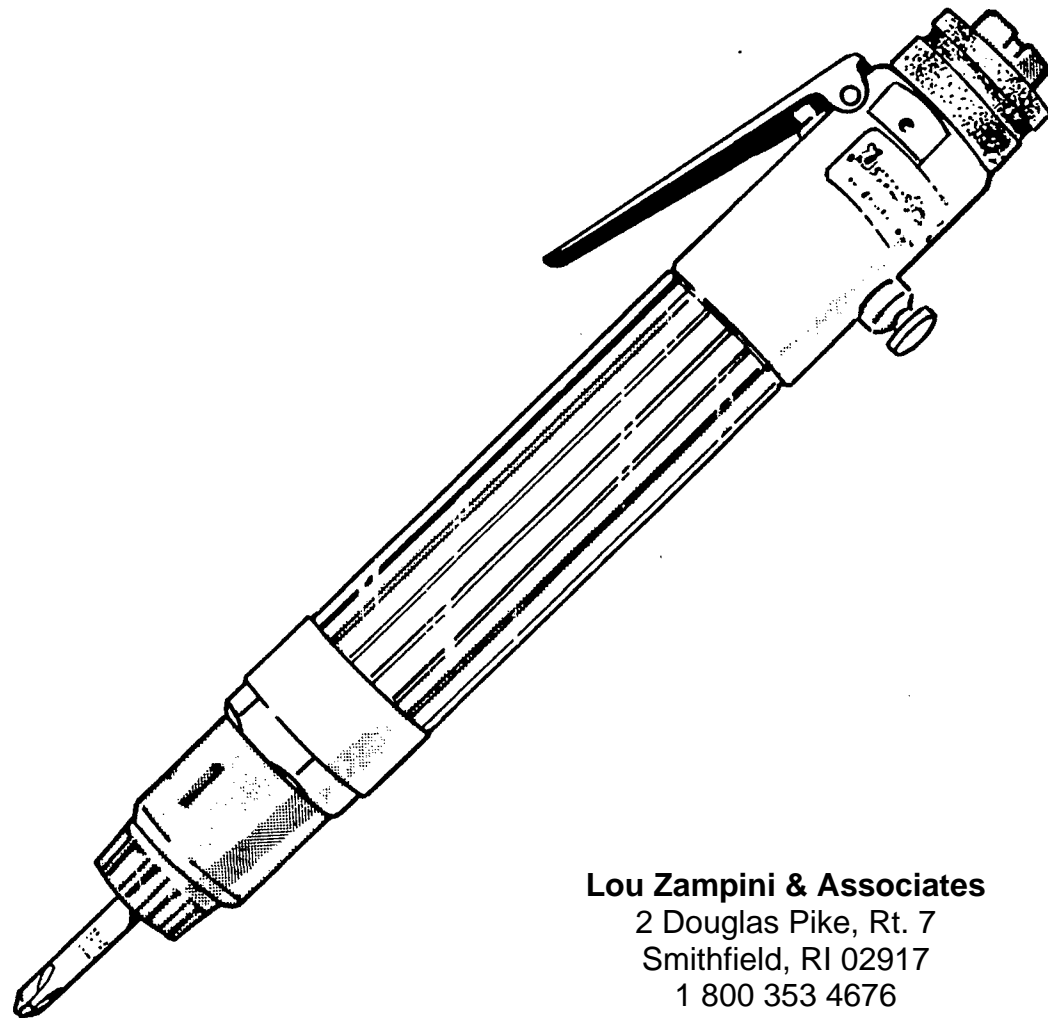

Lou Zampini & Associates

2 Douglas Pike, Rt. 7

Smithfield, RI 02917

1 800 353 4676

FAX 1 401 679 0165

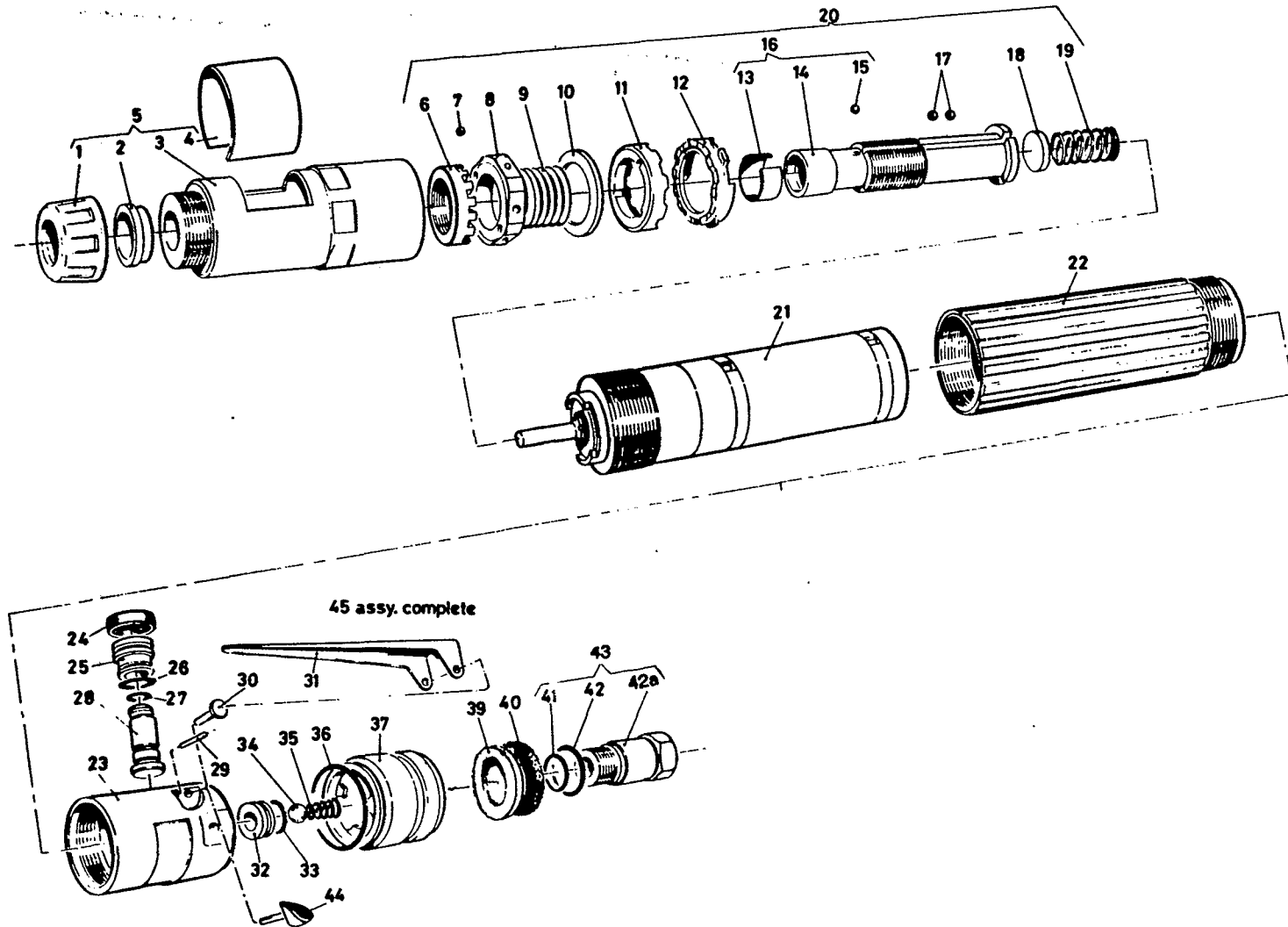

Item No.	Part No.	Description	Qty.	Item No.	Part No.	Description	Qty.
1	74088	Thread Protecting Cap	1				
2	73798	Bearing Bush	1				
3	251533	Clutch Case	1	23	252333	Control Top	1
4	76713	Spring Ring	1	24	157663	Button ('S' tools only)	1
5	251543	Clutch Case Complete	1	25	252533	Guide	1
6	76003	Adjusting Nut	1	*26	203713	'O' Ring	1
7	72228	Ball	3	*27	261213	'O' Ring	1
8	76013	Locking Washer	1	28	252503	Valve Rod ('S' tools only)	1
9	71378	Clutch Spring - Yellow	1	#	306003	Valve Rod ('L' tools only)	1
-	67428	Clutch Spring - Red	1	29	261223	Spring Pin	1
-	68448	Clutch Spring - Green	1	#30	153863	Lever Pin) ('L' tools only)	1
10	67148	Retaining Washer	1	#31	305983	Lever)	1
11	67138	Sliding Clutch	1	32	252383	Valve Seat	1
#12	295493	Fixed Clutch	1	*33	500953	'O' Ring	1
13	86058	Spring Ring - 1/4in. Hex. Drive	1	34	1693	Ball	1
-	67458	Spring Ring - 5/16in. Hex. Drive	1	35	252493	Spring	1
14	76723	Clutch Spindle - 1/4in. Hex. Drive	1	*36	203423	'O' Ring	1
-	76703	Clutch Spindle - 5/16in. Hex. Drive	1	37	252423	Silencer Housing	1
15	66863	Ball - 1/4in. Hex. Drive	1	38	Not Used		1
-	72408	Ball - 5/16in. Hex. Drive	1	39	252483	Spacer	1
16	87163	Clutch Spindle Complete - 1/4in. Hex. Drive	1	40	252453	Sintered Silencer	1
-	87153	Clutch Spindle Complete - 5/16in. Hex. Drive	1	*41	202313	'O' Ring	1
17	72408	Ball	6	*42	268513	'O' Ring	1
18	69853	Seating	1	42a	-	Air Inlet Adaptor Sub-Assembly	1
19	67448	Spring	1	43	261503	Inlet Adaptor - 1/4in. BSP	1
20	295853	Clutch Complete - Yellow - 1/4in. Hex. Drive	1	-	261513	Inlet Adaptor - 1/4in. NPT	1
-	295813	Clutch Complete - Yellow - 5/16in. Hex. Drive	1	44	252983	Insert ('S' tools only)	2
-	295863	Clutch Complete - Red - 1/4in. Hex. Drive	1	45	261333	Control Top Complete -) 1/4in. BSP)	1
-	295823	Clutch Complete - Red - 5/16in. Hex. Drive	1	-	261343	Control Top Complete-) 1/4in. NPT) 'S' tools	1
-	295873	Clutch Complete - Green - 1/4in. Hex. Drive	1	-	261393	Control Top Complete -) 1/4in BSP) 'L' tools	1
-	295833	Clutch Complete - Green - 5/16in. Hex. Drive	1	-	261403	Control Top Complete -) 1/4in. NPT)	1
21	See later Section	Motor and Gearbox	1			Supplied Accessories	
22	252963	Motor Case - 1700 rpm	1	-	154223	Clutch Key	1
-	252973	Motor Case - 1100 rpm	1	-	39433	Suspension Bail	1
-				-	222453	Exhaust Hose	1
				-	235203	Clip - Exhaust Hose	1
				9		Clutch Spring - next in series to extend torque range	1

* Indicates normal replacement items. It is recommended that adequate stocks are held for servicing requirements.

Indicates updated parts.

Always quote tool number, serial number and spare part number when ordering spares.

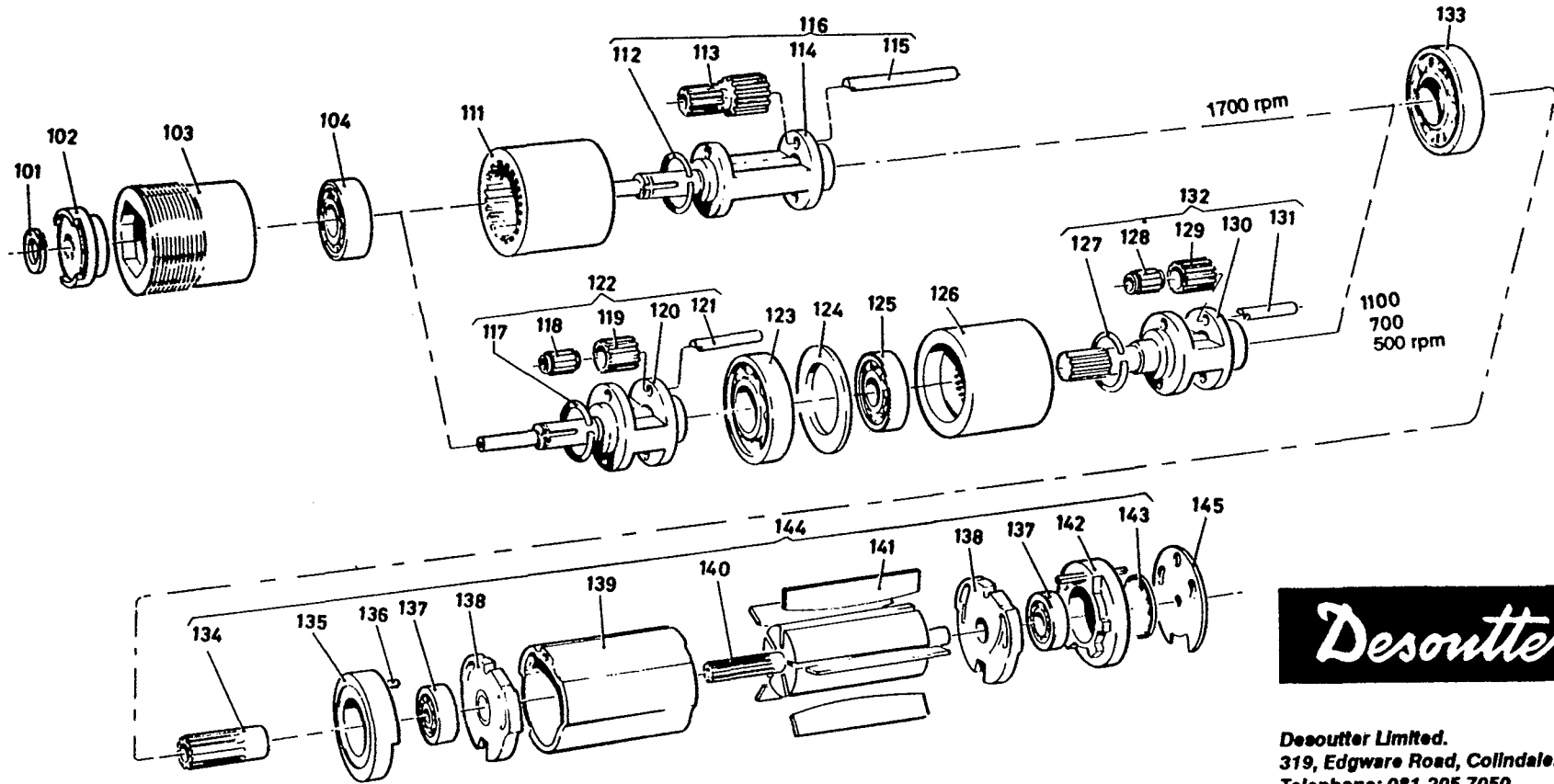

Desoutter Limited.
319, Edgware Road, Colindale, London NW9 6ND.
Telephone: 081-205 7050 Telex: 21392
Fax: 081-205 5167

Printed in England.

8.90

[7]

D8-S/L

Parts List - Motor & Gearbox

D8-S/L

Item No.	Part No.	Description	Qty.	Item No.	Part No.	Description	Qty.	Item No.	Part No.	Description	Qty.
*101	42353	Circlip	1	-	36703	Planet Wheel - 700 rpm & 500 rpm.	2	*133	2413	Bearing	1
102	260023	Dog Clutch	1	120	41573	Planet Cage - 1100 rpm	1				
103				-	42243	Planet Cage - 700 rpm & 500 rpm.	1	134	65373	Pinion - 1100 rpm	1
-	268973	Gear and Nose - 1100 rpm	1	121	80013	Planet Pin - 1100 rpm	2	135	252943	Front Bearing Housing	1
-	252943	Bearing Housing - 1700 rpm	1	-	1453	Planet Pin - 700 rpm & 500 rpm.	2	136	256123	Spring Pin	1
*104	178543	Bearing	1	122	41733	Planet Cage Complete - 1100 rpm	1	*137	33433	Bearing	2
				-	42473	Planet Cage Complete - 700 rpm & 500 rpm.	1	138	254873	Bearing Plate	2
*105	25563	Circlip	1	*123	2413	Bearing	1	139	254853	Cylinder	1
*106	502093	Needle Bearing	2	124	37623	Washer	1	-	41673	Rotor - 1700 rpm	1
107	150813	Planet Wheel	2	*125	2423	Bearing	1	-	98223	Rotor - 1100 rpm	1
108	268903	Planet Cage	1	126	36713	Gear Ring	1	-	37163	Rotor - 500 rpm	1
109	1453	Planet Pin	2					*141	36613	Rotor Blade	5
110	268893	Planet Cage Complete	1	*127	25573	Circlip - 1100 & 700 rpm	1	142	254883	Rear Bearing Housing Complete	1
				#-	37423	Circlip - 500 rpm	1	143	254903	Cap	1
111	41703	Gear Ring	1	*128	502093	Needle Bearing	2	144			
*112	25563	Circlip	1	129	65383	Planet Wheel - 1100 & 700 rpm	2	-	268553	Motor Complete - 1700 rpm	1
113	41683	Planet Wheel	2	#-	36703	Planet Wheel - 500 rpm.	2	-	268603	Motor Complete - 1100 rpm	1
114	41663	Planet Cage	1	130	237313	Planet Cage - 1100 rpm	1	-	268583	Motor Complete - 500 rpm	1
115	41693	Planet Pin	2	-	81473	Planet Cage - 700 rpm	1	145	253003	Gasket	1
116	42463	Planet Cage Complete	1	#-	42273	Planet Cage - 500 rpm	1				
				131	1453	Planet Pin	2				
*117	41623	Circlip - 1100 rpm	1	132	237323	Planet Cage Complete - 1100 rpm	1				
-	37423	Circlip - 700 rpm & 500 rpm.	1	-	81483	Planet Cage Complete - 700 rpm	1				
*118	502093	Needle Bearing - 700 rpm & 500 rpm.	2	#-	42283	Planet Cage Complete - 500 rpm	1				
119	42293	Planet Wheel - 1100 rpm	2								

* Indicates normal replacement items. It is recommended that adequate stocks are held for servicing requirements.

Indicates updated parts
Always quote tool model number, serial number and spare part number when ordering spares.

Customer Notes

REQUIREMENTS

Air Supply

A water free and filtered air supply is required, at a pressure of 6 bar (87lb/lin²), with a flow of 9.4l/s (20cu.ft/min); controlled by a pressure regulator selected from the Desoutter Air Line Service Equipment Catalogue.

Lubrication

Correct lubrication is vital for the maximum performance of the tool and an airline lubricator should be fitted into the system down stream of the filter.

Desoutter recommend the use of an ISO Viscosity Classified Oil, grade number ISO VG 15, in the lubricator.

Accessories

A wide range of screwdriving bits and nutrunning sockets are available and a suitable item should be selected from the Desoutter Accessories Catalogue.

The retention of these items is by spring loaded ball, they require a sharp pull to release.

OPERATING

With the correct accessory fitted into the tool connect the air supply. Grip the tool around the motor case and operate the level/button control. The motor will run but the bit/socket will remain stationary until the tool is pressed onto the fixing that is to be tightened. When the required torque, set by adjusting the clutch spring, is reached the clutch will ratchet; at this point the tool should be withdrawn from the fixing and the lever/button released.

WARNING

- 1) Always disconnect tool from the power supply before attempting any replacement, adjustment, servicing or dismantling.
- 2) Ensure that no loose articles of clothing or cleaning material can be caught by the rotating parts of the tool.
- 3) Always allow the tool to stop before removing work or resting tool.
- 4) Ensure that work piece is securely clamped before commencement of operation — clear all loose items from vicinity.

INITIAL SETTING

When received the torque output of the tool will require setting to match the job requirement.

It is recommended that a trial tightening operation is carried out to determine the amount of adjustment required. The ideal instrument for checking the torque is an electronic peak meter (request information from Desoutter); failing this a dial indicating torque wrench is adequate.

Clutch Adjustment

Rotate spring clip to uncover access hole in clutch case, insert clutch key, supplied with tool, and rotate to obtain the required torque (see illustration).

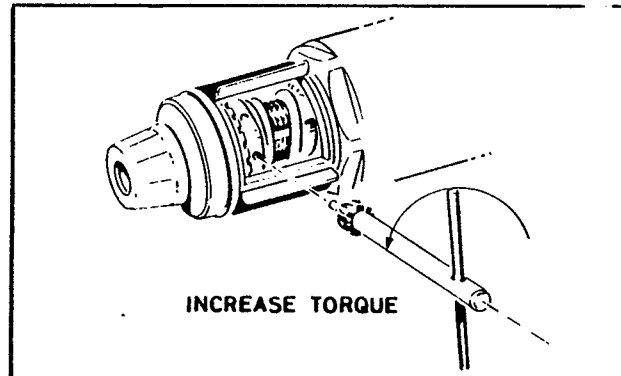

SERVICE REQUIREMENTS

General Notes

Use the following lubricants:

Oil - ISO Viscosity Classified - ISO VG 15, for motors.
Grease - Duckhams Type Q5618, for gears and bearings.
Silicone Grease - Molykote 33, for 'O' rings.

The following tools will be required:

Clamp Block — Part No. 39373 (1 pair)
Hexagon Key — Part No. 277343
Spanner — 32mm
Spanner — 19mm
Circlip Pliers.

The following torque values MUST be used:

Item 1 to Item 5:- Hand tighten
Item 5 to Item 103:- 24.4Nm (18lb.ft)
Item 103 to Item 22:- 30Nm (22lb.ft)
Item 22 to Item 45 :- Hand tighten, faces abutting
Item 43 to Item 23 :- 13.5Nm (10lb.ft)

Replace as necessary all 'O' rings, gaskets, bearings and rotor blades.

Bearings that have a retainer holding the balls in place must be assembled into the tool with the blank face of the retainer to the air flow; in the case of the motor the blank faces must face each other across the rotor.

The threads in this tool are left hand with the exception of the air inlet adaptor.

It is important that the gear and nose/front bearing housing (103) is slackened first, NEVER attempt to unscrew the control top when the above component is fully tightened.

TO DISMANTLE

Mount the motor case (22) between a pair of clamp blocks and clamp firmly in a vice. Unscrew the clutch case (5) and remove the clutch complete (20), release circlip (101) and pull off dog clutch (102).

Using the hexagon key unscrew the gear and nose/front bearing housing (103) then unscrew the control top. Remove the tool from the clamp blocks and push the internal components out of the motor case.

The remainder of the dismantling follows normal engineering practice with reference to the illustration.

TO ASSEMBLE

Assembly Notes.

When locating the motor complete (144) in the control top complete (45) the pin projecting out of rear bearing housing complete (142) must enter the 'R' marked hole in the control top.

It is important that spacer (39) is located the correct way round: concave side to the rear of the tool.

Sub Assemblies

Using the illustration as a guide assemble control top, planet cages and if dismantled the clutch.

The following instructions for the motor complete (144) must be followed:-

Take the rotor (140) and place the rear bearing plate (138), with grooves to rotor, into position. Press bearing (137) onto the rotor so that there is a 0.038mm (0.0015in.) gap between the rotor and the rear bearing plate. Holding the rotor and rear bearing plate assembly with the gear end of the rotor uppermost, slide the cylinder (139) over the rotor.

Locate the rotor blades (141) into their slots in the rotor (140). Place this sub-assembly, gear end of rotor spigot uppermost, onto a fixture which locates only on the rotor rear spigot. Align the location slot in both bearing plates with the pin holes in the cylinder and push on the bearing (137). Press home until the bearing bottoms on the front bearing plate BUT do not preload the bearing. Locate the rear bearing housing (142) with its spring pin onto the motor then, press on the front bearing housing (135) making sure that the spring pins are correctly located. Check for free rotation of the rotor.

Final Assembly

Stand control top on air inlet adaptor, place gasket (145) in position so that the required pin location hole is clear. Remove the rear bearing housing (142) from the motor complete (144) and locate in the control top, load the rest of the motor into position then slide the motor case (22) over the motor and screw fully into the control top. Slide the planet cage assemblies into the motor case checking that as each assembly is located the unit is free to rotate.

Mount the motor case (22) between a pair of clamp blocks and clamp firmly in a vice then using the hexagon key fully tighten the gear and nose/front bearing housing (103). Replace dog clutch (102) and retain with circlip (101), locate the clutch (20) making sure that seating (18) and spring (19) are in place. Screw the clutch case into position, release the tool from the clamps, connect to the air supply and test for correct operation.

Customer Notes