

ESP 6 - Option 1

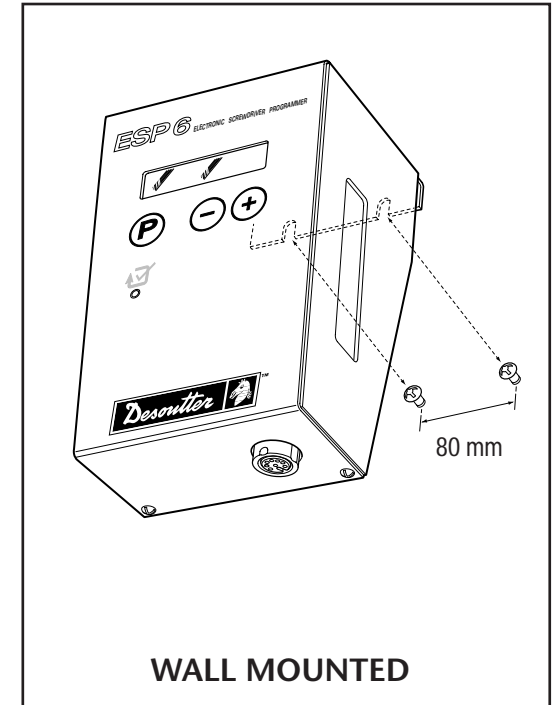

Desoutter Limited Eaton Road Hemel Hempstead Hertfordshire HP2 7DR England

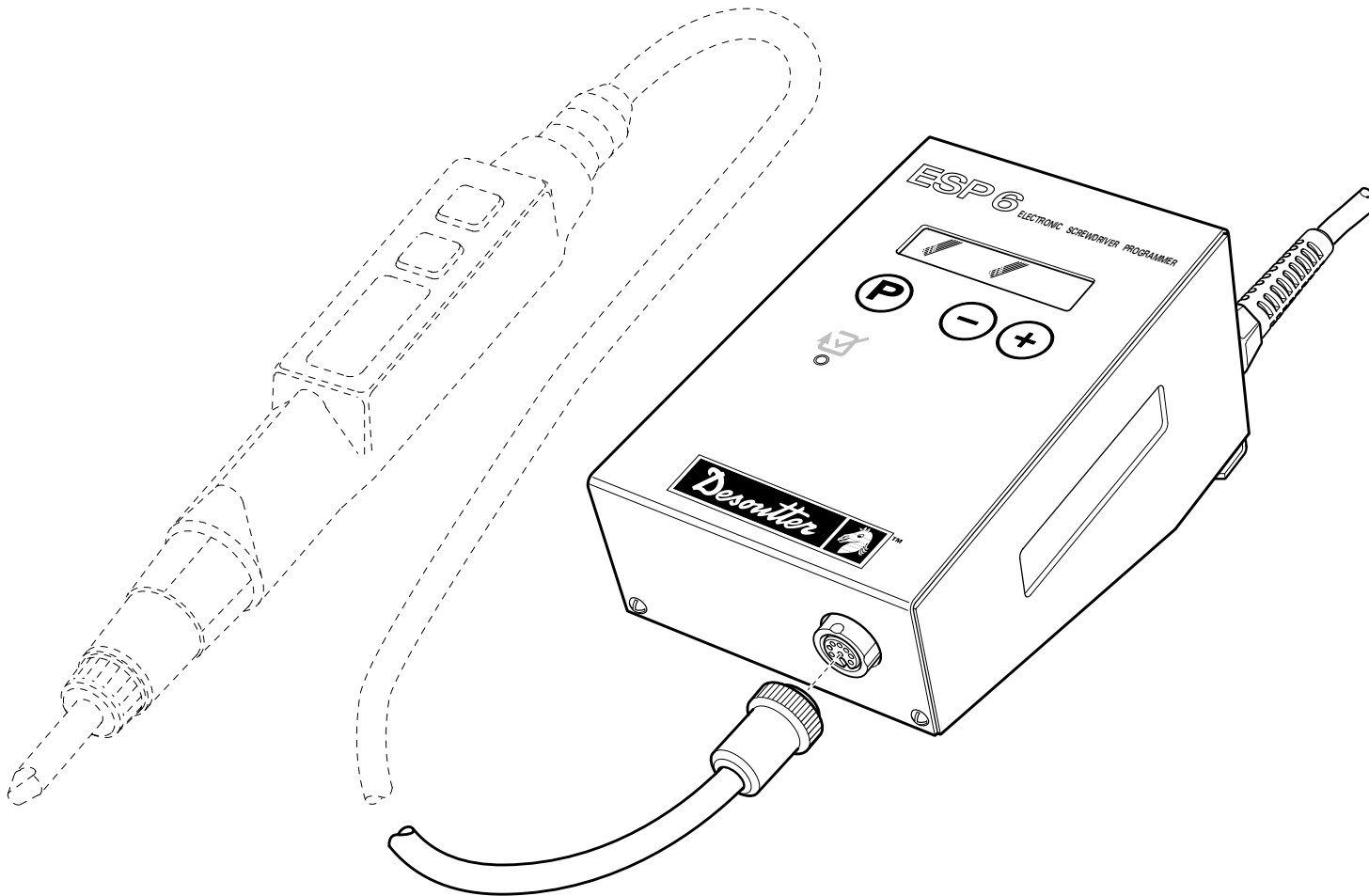

ESP 6 -108232C

GB SERVICING AND
OPERATING INSTRUCTIONS
D WARTUNGSANLEITUNG
BEDIENUNGSANLEITUNG

F MANUEL D'ENTRETIEN
MANUEL D'UTILISATION
E INSTRUCCIONES DE SERVICIO
INSTRUCCIONES DE OPERACIÓN

P INSTRUÇÕES DE MANUTENÇÃO
INSTRUÇÕES DE FUNCIONAMENTO
I ISTRUZIONI PER LA MANUTENZIONE
ISTRUZIONI OPERATIVE

NL ONDERHOUDSINSTRUCTIES
BEDIENINGSINSTRUCTIES

DK SERVICEVEJLEDNING
BETJENINGSVEJLEDNING
N SERVICEINSTRUKSJONER
DRIFTSINSTRUKSJONER

S SERVICEINSTRUKTIONER
BRUKSANVISNING
FIN HUOLTO-OHJEET
KÄYTTÖOHJEET

ESP 6 - Save these Instructions



Desoutter Limited Eaton Road Hemel Hempstead Hertfordshire HP2 7DR England

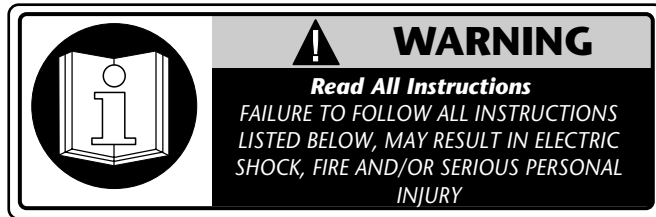

WORK AREA

Keep your work area clean and well lit. Cluttered benches and dark areas invite accidents.

Do not operate power tools in explosive atmospheres, such as in the presence of flammable liquids, gases or dust. Power tools create sparks which may ignite the dust or fumes.

Keep bystanders, children and visitors away while operating a power tool. Distractions can cause you to lose control.

ELECTRICAL SAFETY

Grounded Tools must be plugged into an outlet properly installed and grounded in accordance with all codes and ordinances. Never remove the grounding prong or modify the plug in any way. Do not use ant adaptor plugs. Check with a qualified electrician if you are in doubt as to whether the outlet is properly grounded.

If the tools should electrically malfunction or break down, grounding provides a low resistance path to carry electricity away from the user. Avoid body contact with grounded surfaces such as pipes, radiators, ranges and refrigerators. There is an increased risk of electric shock if your body is grounded.

Don't expose power tools to rain or wet conditions. Water entering a power tool will increase the risk of electric shock.

Do not abuse the cord. Never use the cord to carry the tools or pull the plug from an outlet. Keep cord away from heat, oil, sharp edges or moving parts. Replace damaged cords immediately. Damaged cords increase the risk of electric shock.

When operating a power tool outside, use an outdoor extension cord marked "W-A" or "W". These cords are rated for outdoor use and reduce the risk of electric shock.

PERSONAL SAFETY

Stay alert, watch what you are doing and use common sense when operating a power tool. Do not use tool while tired or under the influence of drugs, alcohol or medication. A moment of

inattention while operating power tools may result in serious personal injury.

Dress properly. Do not wear loose clothing or jewellery. Contain long hair. Keep your hair, clothing and gloves away from moving parts. Loose clothes, jewellery or long hair can be caught in moving parts.

Avoid accidental starting. Be sure switch is off before plugging in. Carrying tools with your finger on the switch or plugging in tools that have the switch on invites accidents.

Remove adjusting keys or switches before turning the tool on. A wrench or key that is left attached to a rotating part of the tool may result in personal injury.

Do not overreach. Keep proper footing and balance at all times. Proper footing and balance enables better control of the tool in unexpected situations.

Use safety equipment. Always wear eye protection. Dust mask, non-skid safety shoes, hard hat or hearing protection must be used for appropriate conditions.

Hold tool by insulated gripping surfaces when performing an operation where the cutting tool may contact hidden wiring or its own cord. Contact with a "live" wire will make exposed metal parts of the tool "live" and shock the operator.

Store idle tools in dry and high or locked-up place. Out of reach of children.

TOOL USE AND CARE

Use clamps or other practical way to secure and support the workpiece to a stable platform. Holding the work by hand or against the body is unstable and may lead to loss of control.

Do not force tool. Use the correct tool for your application. The correct tool will do the job better and safer at the rate for which it is designed.

Do not use the tool if switch does not turn it on or off. Any tool that cannot be controlled with the switch is dangerous and must be repaired.

Disconnect the plug from the power source before making any adjustments, changing accessories or storing the tool. Such preventive safety measures reduce the risk of starting the tool accidentally.

Store idle tools out of reach of children and other untrained persons. Tools are dangerous in the hands of untrained users.

Maintain tools with care. Keep cutting tools sharp and clean. Properly maintained tools, with sharp cutting edges are less likely to bind and are easier to control.

Check for misalignment or binding of moving parts, breakage of

parts, and any other condition that may affect the tools operation. If damaged, have the tool serviced before using. Many accidents are caused by poorly maintained tools.

Use only accessories that are recommended by the manufacturer for your model. Accessories that may be suitable for one tool, may become hazardous when used on another tool.

Don't use tool for purpose not intended. For example don't use circular saw for cutting tree limbs or logs.

SERVICE

Tool service must be performed only by qualified personnel. Service or maintenance performed by unqualified personnel could result in a risk of injury.

When servicing a tool use only identical replacement parts. Follow instructions in the maintenance section of this manual. Use of unauthorised parts or failure to follow Maintenance Instructions may create a risk of electric shock or injury.

SAVE THESE INSTRUCTIONS

ESP-6 Conservez les Instructions



Desoutter Limited Eaton Road Hemel Hempstead Hertfordshire HP2 7DR England



AIRE DE TRAVAIL

Veillez à ce que l'aire de travail soit propre et bien éclairée. Le désordre et le manque de lumière favorisent les accidents. **N'utilisez pas d'outils électriques dans une atmosphère explosive, par exemple en présence de liquides, de gaz ou de poussières inflammables.** Les outils électriques créent des étincelles qui pourraient enflammer les poussières ou les vapeurs. **Tenez à distance les curieux, les enfants et les visiteurs pendant que vous travaillez avec un outil électrique.** Ils pourraient vous distraire et vous faire faire une fausse manœuvre.

SÉCURITÉ ÉLECTRIQUE

Les outils mis à la terre doivent être branchés dans une prise de courant correctement installée et mise à la terre conformément à tous les codes et règlements pertinents. **Ne modifiez jamais la fiche de quelque façon que ce soit, par exemple en enlevant, la broche de mise à la terre. N'utilisez pas d'adaptateur de fiche. Si vous n'êtes pas certain que la prise de courant est correctement mise à la terre, adressez-vous à un électricien qualifié.** En cas de défilance ou de déféctuosité électrique de l'outil, une mise à la terre offre un trajet de faible résistance à l'électricité qui autrement risquerait de traverser l'utilisateur. **Évitez tout contact corporel avec des surfaces mises à la terre (tuyauterie, radiateurs, cuisinières, réfrigérateurs, etc.).** Le risque de choc électrique est plus grand si votre corps est en contact avec la terre.

N'exposez pas les outils électriques à la pluie ou à l'eau. La présence d'eau dans un outil électrique augmente le risque de choc électrique. **Ne maltraitez pas le cordon. Ne transportez pas l'outil par son cordon et ne débranchez pas la fiche en tirant sur le cordon. N'exposez pas le cordon à la chaleur, à des huiles, à des arêtes vives ou à des pièces en mouvement. Remplacez immédiatement un cordon endommagé.** Un cordon endommagé augmente la risque de choc électrique.

Lorsque vous utilisez un outil électrique à l'extérieur, employez

un prolongateur pour l'extérieur marqué "W-A" ou "W". Ces cordons sont faits pour être utilisés à l'extérieur et réduisant le risque de choc électrique.

SÉCURITÉ DES PERSONNES

Restez alerte, concentrez-vous sur votre travail et faites preuve de jugement. N'utilisez pas un outil électrique si vous êtes fatigué ou sous l'influence de drogues, d'alcool ou des médicaments. Un instant d'inattention suffit pour entraîner des blessures graves.

Habilitez-vous convenablement. Ne portez ni vêtements flottants ni bijoux. Confinez les cheveux longs. N'approchez jamais les cheveux, les vêtements ou les gants des pièces en mouvement.

Des vêtements flottants, des bijoux ou des cheveux longs risquent d'être happés par des pièces en mouvement.

Métez-vous d'un démarrage accidentel. Avant de brancher l'outil, assurez-vous que son interrupteur est sur ARRÊT. Le fait de transporter un outil avec le doigt sur la détente ou de brancher un outil dont l'interrupteur est en position MARCHE peut mener tout droit à un accident.

Enlevez les clés de réglage ou de serrage avant de démarrer l'outil. Une clé laissée dans une pièce tournante de l'outil peut provoquer des blessures.

Ne vous penchez pas trop en avant. Maintenez un bon appui et restez en équilibre en tout temps. Une bonne stabilité vous permet de mieux réagir à une situation inattendue.

Utilisez des accessoires de sécurité. Portez toujours des lunettes ou un visièrre. Selon les conditions, portez aussi un masque antipoussière, des bottes de sécurité antidérapantes, un casque protecteur et/ou un appareil antibruit.

Tenez l'outil par ses surfaces de prise isolées pendant toute opération où l'outil de coupe pourrait venir en contact avec un câblage dissimulé ou avec son propre cordon. En cas de contact avec un conducteur sous tension, les pièces métalliques à découvert de l'outil transmettraient un choc électrique à l'utilisateur.

UTILISATION ET ENTRETIEN DES OUTILS

Immobilisez le matériau sur une surface stable au moyen de brides ou de toute autre façon adéquate. Le fait de tenir la pièce avec la main ou contre votre corps offre une stabilité insuffisante et peut amener un dérapage de l'outil.

Ne forcez pas l'outil. Utilisez l'outil approprié à la tâche. L'outil correct fonctionne mieux et de façon plus sécuritaire. Respectez aussi la vitesse de travail qui lui est propre.

N'utilisez pas un outil si son interrupteur est bloqué. Un outil que vous ne pouvez pas commander par son interrupteur est dangereux

et doit être réparé.

Débranchez la fiche de l'outil avant d'effectuer un réglage, de changer d'accessoire ou de ranger l'outil. De telles mesures préventives de sécurité réduisent le risque de démarrage accidentel de l'outil.

Rangez les outils hors de la portée des enfants et d'autres personnes inexpérimentées. Les outils sont dangereux dans les mains d'utilisateurs novices.

Prenez soin de bien entretenir les outils. Les outils de coupe doivent être toujours bien affûtés et propres. Des outils bien entretenus, dont les arêtes sont bien tranchantes, sont moins susceptibles de coincer et plus faciles à diriger.

Soyez attentif à tout désalignement ou coincement des pièces en mouvement, à tout bris ou à toute autre condition préjudiciable au bon fonctionnement de l'outil. Si vous constatez qu'un outil est endommagé, faites-le réparer avant de vous en servir. De nombreux accidents sont causés par des outils en mauvais état.

N'utilisez que des accessoires que le fabricant recommande pour votre modèle d'outil. Certains accessoires peuvent convenir à un outil, mais être dangereux avec un autre.

RÉPARATION

La réparation des outils électriques doit être confiée à un réparateur qualifié. L'entretien ou la réparation d'un outil électrique par un amateur peut avoir des conséquences graves.

Pour la réparation d'un outil, n'employez que des pièces de rechange d'origine. Suivez les directives données à la section "Réparation" de ce manuel. L'emploi de pièces non autorisées ou le non-respect des instructions d'entretien peut créer un risque de choc électrique ou de blessures.

CONSERVEZ LES INSTRUCTIONS

ESP 6 - Option 1 Parts List



Desoutter Limited Eaton Road Hemel Hempstead Hertfordshire HP2 7DR England

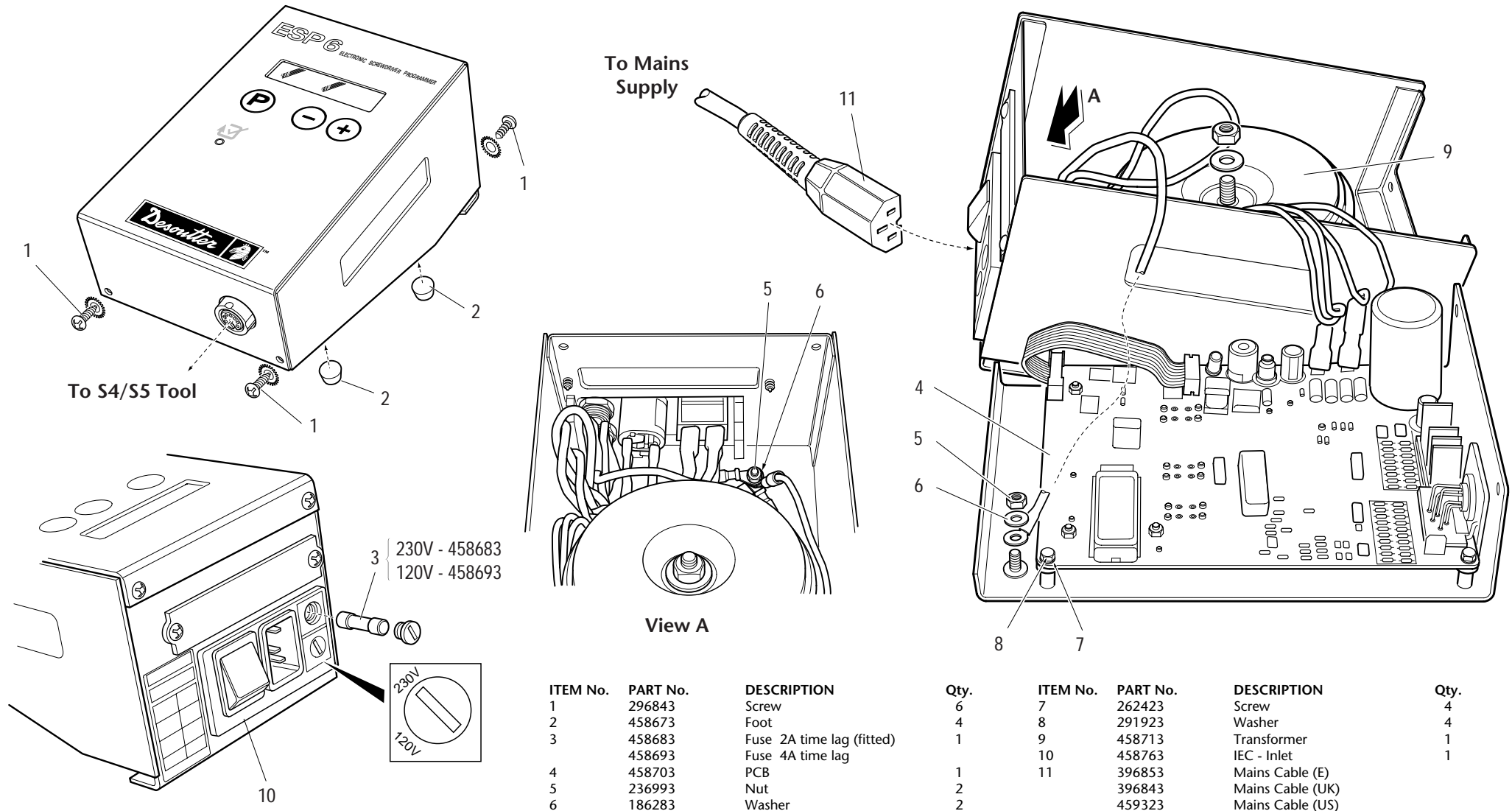

ESP 6 - Option 1 Programming Description



Desoutter Limited Eaton Road Hemel Hempstead Hertfordshire HP2 7DR England



WARNING

To reduce risk of injury, everyone using, installing, repairing, maintaining, changing accessories on, or working near this tool must read and understand these instructions before performing any such task.



WARNING

**THIS UNIT MUST BE EARTHED
THIS UNIT MUST NOT BE USED IN
EXPLOSIVE ATMOSPHERES.
DO NOT OPERATE WITH COVERS REMOVED.
THE TOOL SETTING OR OPERATIONAL
TECHNIQUE MUST NOT ALLOW A MOTOR
STALL CONDITION TO OCCUR.**

STATEMENT OF USE

Controller to be used with electric screwdriver models S4X2A, S4X2M, S4Y2A, S5V2A, S5V2M and S5Z2A. No other use permitted.

OPERATION DATA

Rated Voltage	230/120V
Rated Input	160VA
Rated Current	2A (230V), 4A (120V)
ConstructionClass	1
Mass	2.65Kg

MAINTENANCE INSTRUCTIONS

All servicing of the unit to be carried out by Desoutter Authorised Representatives.

PROGRAMMING DESCRIPTION - OPTION '1'

To be used in conjunction with S5V2A, S5V2M, S4X2A and S4X2M tools.

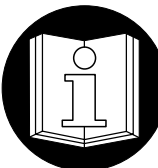

CAUTION

UNIT DAMAGE- BEFORE APPLYING POWER TO THE UNIT, MAKE SURE THAT THE VOLTAGE SELECTOR AND FUSE ARE SET TO THE CORRECT INPUT VOLTAGE. DAMAGE TO THE UNIT CAN OCCUR IF THE LINE VOLTAGE IS NOT SET CORRECTLY.

To change the line voltage selection.

1. Disconnect the unit from the power supply.
2. Carefully adjust the voltage selector by inserting a screwdriver into the slot and turn clockwise for 230V or anti-clockwise for 120V until the arrow aligns with the correct voltage.
3. Carefully insert in the fuse holder slot and turn anti-clockwise.
4. Remove fuse and check amperage rating 230V -2A, 120V -4A.
5. Insert the fuse and turn slot in fuse holder clockwise.

USER INTERFACE

There are 3 different functions to be programmed on the ESP6 basic version.

- SET-UP ROUTINE - allows definition of language version, thread direction, password enable and Factory Default Parameters.
- OPERATIONAL ROUTINE - allows for fastening applications.
- PARAMETER CHANGE ROUTINE - enables the user to adapt the unit to his specific requirements with selectable password protection. The choice of parameters that can be accessed depends on the installed option module.

The user interface consists of a one line 16 character display and 3 keys.

In the following description the 3 keys are referred to as mode (P), down (-) and up (+) key.

FUNCTION - SET-UP ROUTINE

To enter the Set - Up - Routine, the mode key (P) must be pressed and held before turning power on.

Release the Mode key **after** the following is displayed.

ESP6 SETUP-MODE

The message disappears as soon as the mode key (P) is released:

Parameter 1:

LANGUAGE GB

This parameter allows the operator to select the language used for the messages in the display. Languages held in the memory are English (GB), German (D), French (F), Italian (I), Spanish (E), Dutch (NL), Portuguese (P), Danish (DK), Norwegian (N), Swedish (S), and Finnish (FIN). Select language by depressing (-) and (+) keys. To store the language selection, depress and release mode key (P).

Parameter 2:

THREADTYP RHR

This parameter allows the operator to prepare the system for the use with right hand thread screws (RHR) or left hand thread screws (LHR).

Select by depressing (-) and (+) keys. To store the thread selection, depress and release mode key (P).

Parameter 3:

PASSWORD 000

This parameter allows the operator to enter the factory set password (115) by depressing (-) and (+) keys.

To store selection, depress and release mode key (P). If an incorrect password is entered, the display will return to parameter "1". If the correct password has been entered, the following is displayed (YES if already enabled, NO if not currently enabled):

PASSWORD YES

Select YES or NO by depressing (-) or (+) keys. If YES selected, every time the parameter change mode is selected to change parameters, the password will be asked for. To store selection, depress and release mode key (P).

ESP 6 - Option 1 Programming Description



Desoutter Limited Eaton Road Hemel Hempstead Hertfordshire HP2 7DR England

Parameter 4:

FACTORY DEFAULT

This parameter allows the operator to restore the factory Default Parameters for the ESP 6 Hardware Option conditions existing. (i.e. No Option Board, Option Board A, B or C.). To restore the factory parameters press and hold either the (-) or (+) keys and then press and hold the mode (P) key for approximately 3 seconds. After 3 seconds the display will change to:

EEPROM INIT

Release the keys and approximately 2 seconds later the following is displayed:

EEPROM INIT OK!

At this point the Set up menu can be repeated or be exited.

This completes the Set-up Mode function.

Exit of the Set-up Mode is by pressing the mode key (P) for 3 seconds which will store the changed values and the following is displayed:

SETUPMODE CLOSED

If there is no user input for more than 60 seconds, any parameters set will **not be** stored!

FUNCTION - OPERATIONAL ROUTINE:

Power 'ON' - After switching the unit ON a self-test is executed, during which the software release and installed option board, if installed, is displayed:

ESP6 V.2.9 1

Then the recognised tool is displayed:

S5 CONNECTED

S4 CONNECTED

NO TOOL

If no tool is connected, the systems will present the display NO TOOL, until a tool is connected.

Note: If tool is connected and NO TOOL is displayed, this indicates a tool motor circuit failure, (e.g. Tool cable, tool wiring or defective motor).

SPECIAL FUNCTIONS:

Operator Safety - To remove screwdriver bit, first disable the tool by depressing both buttons on the tool for a minimum of 3 seconds and the following is displayed:

TOOL DISENGAGED

To re-instate tool operation, depress either button on the tool for a minimum of 2 seconds.

Fault Diagnosis - In the event of a fault occurring with the unit the following will be displayed:

ERROR 010

Message Indication: ERROR 010 - Over-current, the current drawn by the tool exceeds the maximum value for too long a period eg. no operation of clutch. This can also be due to programming too slow a speed for the programmed current.
ERROR 011 - Short-circuit, excessive current drawn by the tool due to defect within tool or wiring.
ERROR 012 - EPROM error.

To re-set ESP 6 after ERROR message and resolving the problem (if not programming related), switch 'OFF' unit for a minimum of 15 seconds, then switch back 'ON' and correct parameters if necessary.

FUNCTION - PARAMETER CHANGE MODE:

A tool does not have to be connected to carry out parameter changes.

Note: When fitting or removing a new option board, all parameters **MUST** be rechecked. Alternatively, reload the Factory Default values and change parameters as required.

Parameter - VALUES:

To set-up specific parameter values, depressing the mode key (P) for 3 seconds enters the parameter change mode where the following is displayed:

PARAMETER MODE

If the password feature has been enabled in the "Set-Up, routine" described earlier in this document (i.e. Password "YES"), the following is displayed when the mode key is released:

PASSWORD 000

If a password has been enabled, enter using up key (increased +) or down key (decreased -). To validate the number depress and release the mode key (P). If the wrong password is used the unit will return to the pre-set operational mode with no parameter changes.

Note: If no password has been selected this operation will be bypassed and the first parameter will be presented to the operator.

When the mode key is next depressed and released the first parameter is presented to the user. The user can step through a list of parameters by pressing the mode key. There is always one parameter presented at one time. This parameter can be changed by the down (decreased -) or up key (increased +). By pressing the mode key (P), a changed value is stored temporarily and the next parameter is presented. If the mode key (P) is pressed for greater than 3 seconds, all parameter changes are saved, the parameter change mode is closed and the unit resumes normal operation. The following is displayed after the 3 second period and disappears when the key is released:

PARAMETER STORED

ESP 6 - Option 1 Programming Description



Desoutter Limited Eaton Road Hemel Hempstead Hertfordshire HP2 7DR England

The Set-up and the Parameter Mode will both be exited automatically, if there is no user input for more than 60 seconds. In this case NO changes will be stored, and the programme will operate to the original set values.

Parameter - TOOL/MODE:

These parameters adapt the system to the tool in use, and are available on all versions.

The S4 and S5 tools are available in push start ("A", "Y" and "Z" tools) and manual start ("M" tool) versions. (Note that "Y" and "Z" tools can only be used with Options 4 and 5).

The TOOL parameter enables selection of MANU or PUSH, the system will be configured for the equivalent operation. Only in the selection of TOOL = PUSH will the next parameter MODE be shown.

The MODE parameter enables selection of either PUSH-START (Auto start forward or for reverse, depress reverse button and then push-start), or COMBI-START (Combi-start means the forward or reverse button must be depressed as well as push to start the tool).

SUMMARY OF DISPLAY CONTENTS IN PARAMETER MODE:

TOOL	MANU	MANU/PUSH
MODE	COMBI	PUSH/COMBI

© Copyright 1999, Desoutter, HP2 7DR, UK.

All rights reserved. Any unauthorized use or copying of the contents or part thereof is prohibited. This applies in particular to trademarks, model denominations, part numbers and drawings. Use only authorized parts. Any damage or malfunction caused by the use of unauthorized parts is not covered by Warranty or Product Liability.