

# ESP 6 -Option 3 and 4

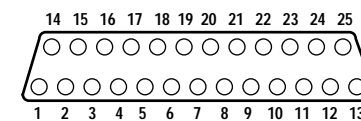

Desoutter Limited Eaton Road Hemel Hempstead Hertfordshire HP2 7DR England

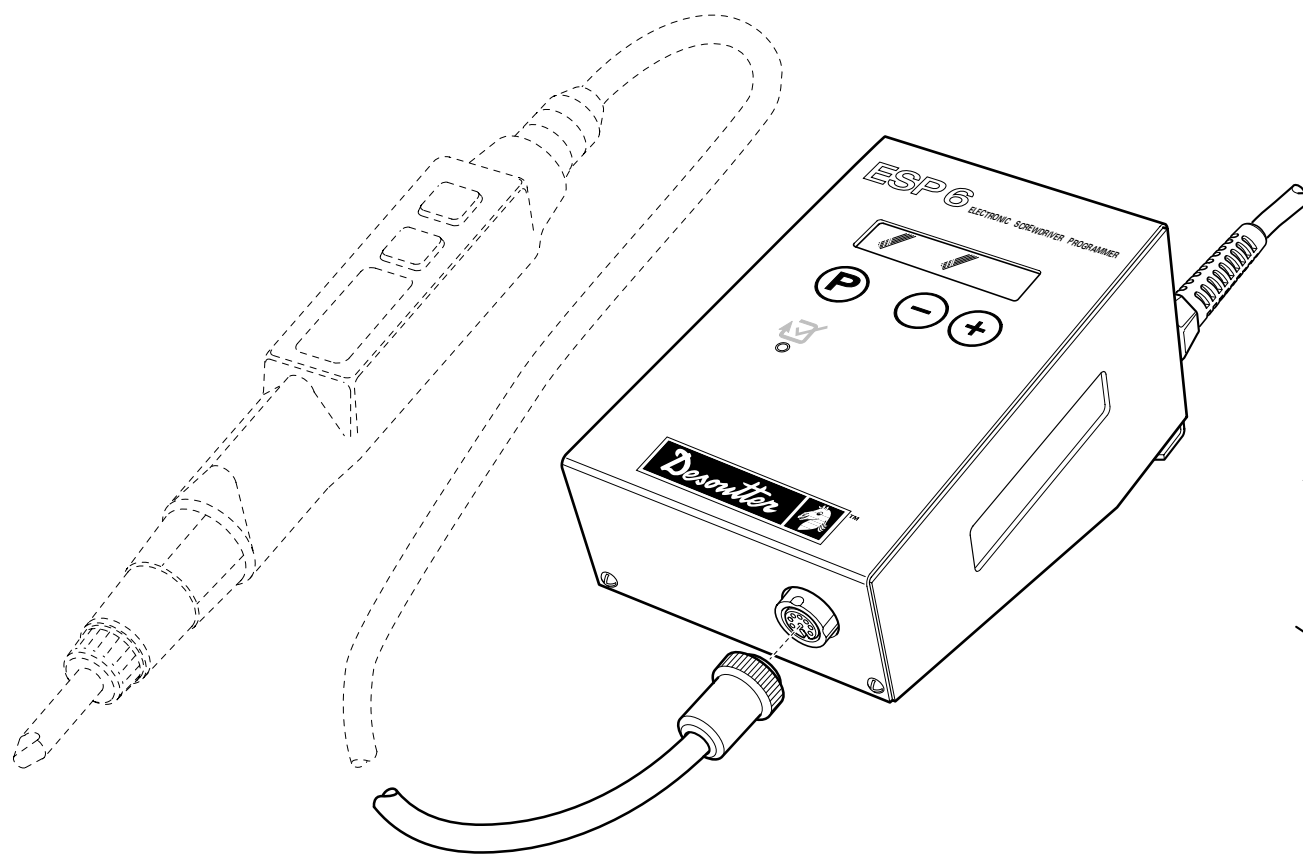

VIEW A

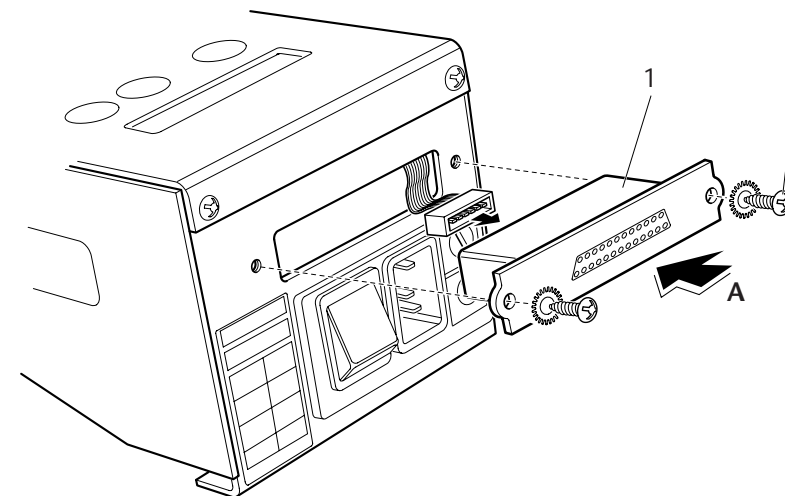

ESP 6 -108252-C

ITEM No.	PART No.	DESCRIPTION	Qty.
1	108252	Option Board B	1
2	296843	Screw	2

**GB** SERVICING AND OPERATING INSTRUCTIONS  
**D** WARTUNGSANLEITUNG BEDIENUNGSANLEITUNG

**F** MANUEL D'ENTRETIEN MANUEL D'UTILISATION  
**E** INSTRUCCIONES DE SERVICIO INSTRUCCIONES DE OPERACIÓN

**P** INSTRUÇÕES DE MANUTENÇÃO INSTRUÇÕES DE FUNCIONAMENTO  
**I** ISTRUZIONI PER LA MANUTENZIONE ISTRUZIONI OPERATIVE

**NL** ONDERHOUDSINSTRUCTIES BEDIENINGSINSTRUCTIES

**DK** SERVICEVEJLEDNING BETJENINGSVEJLEDNING  
**N** SERVICEINSTRUKSJONER DRIFTSINSTRUKSJONER

**S** SERVICEINSTRUKTIONER BRUKSANVISNING  
**FIN** HUOLTO-OHJEET KÄYTTÖOHJEET

# ESP 6 - Option 3 and 4 Programming Description



**Desoutter Limited** Eaton Road Hemel Hempstead Hertfordshire HP2 7DR England

## STATEMENT OF USE:

This control board to be used in conjunction with Desoutter unit ESP6 (108232). No other use permitted.

## Programming Description - Option '3/4'

To be used in conjunction with S5V2A, S5V2M, S5Z2A, S4X2A, S4Y2A and S4X2M

## FUNCTION - PARAMETER CHANGE MODE:

A tool does not have to be connected to carry out parameter changes.

**Note:** When fitting or removing a new option board, all parameters MUST be rechecked. Alternatively, reload the "Factory Default" values and change parameters as required.

## Parameter - VALUES:

To set-up specific parameter values, depressing the mode key (P) for 3 seconds enters the parameter change mode where the following is displayed:

**PARAMETER MODE**

If the password feature has been enabled in the "Set-Up-Routine" described in Option 1 (i.e. Password "Yes"), the following is displayed when the mode key is released:

**PASSWORD 000**

If a password has been enabled enter using up key (increased +) or down key (decreased -). To validate the number depress and release the mode key (P). If the wrong password is used the unit will return to the pre-set operational mode with no parameter changes.

**Note:** If no password has been selected this operation will be bypassed and the first parameter will be presented to the operator.

When the mode key is next depressed and released the first parameter is presented to the user. The user can step through a list of parameters by pressing the mode key. There is always one parameter presented at one time. This parameter can be changed by the up key (increased +) or down key (decreased -). By pressing

the mode key (P) a changed value is stored temporarily and the next parameter is presented. If the mode key (P) is pressed for greater than 3 seconds, all parameter changes are saved, the parameter change mode is closed and the unit resumes normal operation. The following is displayed after the 3 second period, and disappears when the key is released.

**PARAMETER STORED**

The set-up and the parameter mode will both be exited automatically, if there is no user input for more than 60 seconds. In this case NO changes will be stored, and the programme will operate to the original set values.

## Parameter: TOOL/MODE:

Set parameters as "Basic version".

## Parameter: EXTERNAL FORWARD:

The parameter can be configured as OFF, AND or ONLY and is used in conjunction with the I/O porting.  
OFF: means inactive, so only the tool start (button and/or push) will be active.

AND: means that the tools start (button and/or push) and the external signal must be supplied to start the operation.  
ONLY: means that the fastening or reverse operation will be triggered only by the corresponding external signal.

**Note:** If TOOL has been programmed as PUSH, the ONLY function, although displayed, will be stored as AND.

## Parameter: EXTERNAL REVERSE:

The parameter can be configured as OFF, AND or ONLY and is used in conjunction with the I/O porting.  
OFF: means inactive, so only the tool start (button and/or push) will be active.

AND: means that the tools start (button and/or push) and the external signal must be supplied to start the operation.  
ONLY: means that the fastening or reverse operation will be triggered only by the corresponding external signal.

**Note:** If TOOL has been programmed as PUSH, the ONLY function, although displayed, will be stored as AND.

## Parameter: EXTERNAL STOP:

This programme can be selected as NO or YES and is used in conjunction with the I/O porting.

NO: means inactive.

YES: means an external signal is required to stop the fastening (i.e. The tool is being used to position a fastener/component to a specific position, rather than to a torque). If the clutch or current cut-off operation occurs before the external signal, the tightening will be rated as NOK (cycle not completed).

## Parameter: SELECT GROUP:

This parameter can be set to EXT, 1, 2, 3 or 4 and is used in conjunction with the I/O porting.

EXT: selected, the actual used and edited parameter group depends on the corresponding digital inputs.

With 1, 2, 3 or 4 selected, the parameter group to be used or edited, will be selected by the number programmed via the display.

With EXT selected, the parameter group to be used or edited, will be selected using the External I/O PROG SEL 1 and PROG SEL 2 lines.

Changes on the PROG-SEL inputs will be disregarded during an already started tightening.

## Parameter: SLOW TIME, SLOW SPEED:

If the Slow Time is selected with a value greater than 0, the parameter "Slow Speed" will appear and a value can be selected. The tool will start with selected slow speed and will then switch automatically to the programmed FAST or FINAL selected speed after the slow time has elapsed. If the slow start is set to 0, the parameter slow speed will be skipped. The slow time/speed parameters apply only to the fastening operation.

## Parameter: FAST TIME, FAST SPEED:

If the fast time is selected with a value greater than 0, the parameter "Fast Speed" will appear and a value can be selected. The tool will run at the selected fast speed and will then switch automatically to the programmed FINAL selected speed after the fast time has elapsed.

**Note:** To ensure correct tightening of fastener, the change from fast speed to final speed must occur before the total rundown time of the fastener.

The Fast Time/Speed parameters apply only to the fastening operation.

# ESP 6 - Option 3 and 4 Programming Description



**Desoutter Limited** Eaton Road Hemel Hempstead Hertfordshire HP2 7DR England

**Parameter: FINAL TIME, FINAL SPEED:**

The final time and final speed selection will apply after the slow and fast time (if programmed). The tool operates at this speed until either the shut-off operation occurs or the set time if programmed has elapsed. An "ERR - 5" error will be reported should the "Final Time" timeout before the operation has completed.

**Parameter: SPEED REVERSE:**

This is the speed used for reverse operation.

**Parameter: PRE-REVERSE:**

A reverse operation followed by a tightening operation can be selected. This will mean that the tool will first run in reverse for the programmed "Pre-Reverse" time, and will then automatically run in the forward direction until clutch or current shut-off has occurred.

To activate pre-reverse, program the "Pre-Reverse" time and "Speed Reverse" for reverse speed, the following parameters may then be selected as required slow time/speed, fast time/speed and final time/speed. The cycle will be terminated on completion with a valid clutch or current shut-off signal and an OK (cycle complete) signal. The tool will also stop, if the tool start or external start condition is released before the clutch or current shut off has occurred. This will result in a NOK (cycle not complete) condition.

**Parameter: AUTO-REVERSE (S5V2M, S5Z2A, S4X2M and S4Y2A only):**

An auto-reverse time period can be selected. This will mean, that after clutch or current shut-off has occurred the tool will automatically reverse and run for the defined time and then stop. The auto reverse operation will only be executed, if the fastening cycle had been executed with a valid clutch shut off signal. The cycle will be terminated on completion of the complete programmed auto reverse time, with an OK (cycle complete) signal.

The tool will also stop, if the tool start or external start condition is released before the clutch or current shut-off has occurred or before the complete auto-reverse time has elapsed. This will result in a NOK (cycle not completed) condition.

**Parameter: CURRENT (S5Z2A and S4Y2A only).**

Current shut-off can be selected either OFF (i.e. For clutch shut-off tools), or 25% to 100 % for stall torque tools.

**Note:** The programmed Final Speed value will be reduced "internally " to the programmed current value if a current value less than the final speed value is entered. (i.e. The actual final speed will be reduced). If a current value greater than the programmed final speed is entered, the final speed value will remain unchanged. If a final speed is programmed that is less than the existing current value and the existing final speed, then the tool speed will be reduced.

**Summary of display contents in parameter mode:**

TOOL	PUSH	MANU/PUSH
MODE	PUSH	PUSH/COMBI
EXT . FORWARD	OFF	OFF/AND/ONLY
EXT . REVERSE	OFF	OFF/AND/ONLY
EXT . STOP	OFF	OFF/ON
SELECT GROUP	EXT	EXT/1/2/3/4
1 : SLOW TIME	0 . 3	OFF, 0.1 . . . 9.9 sec
1 : SLOW SPEED	40 %	20% . . . 100%
1 : FAST TIME	0 . 3	OFF, 0.1 . . . 9.9 sec
1 : FAST SPEED	60 %	25% . . . 100%
1 : FINAL TIME	5 . 0	OFF, 0.1 . . . 9.9 sec
1 : FINAL SPEED	80 %	25% . . . 100%
1 : REVERSE	60 %	20% . . . 100%
1 : PRE REVERSE	OFF	OFF, 0.1 . . . 9.9 sec
1 : AUTO REVERS	OFF	OFF, 0.1 . . . 9.9 sec
1 : CURRENT	OFF	OFF, 25% . . . 100%

**I/O Signals:**

The option modules add the following digital input/output capabilities to the system.

IN: EXTERNAL FORWARD IN: EXTERNAL REVERSE

IN: EXTERNAL STOP.

IN: PROG-SEL 1 IN: PROG-SEL 2

OUT: CYCLE COMPLETE (OK), same operation as LED on front panel.

OUT: NOT COMPLETED (NOK).

**Functionality of Inputs:**

- > EXTERNAL FORWARD and EXTERNAL REVERSE are for external operation of the tool.
- > EXTERNAL STOP NO/YES. When "External Stop" is programmed YES, this input will cause the tool to stop.
- > PROG - SEL 1 and PROG - SEL 2 are used to select program groups 1, 2, 3 or 4 when "SELECT GROUP" is programmed to EXT.

**Functionality of Outputs:**

- > The outputs are switched inactive with every trigger operation, which sets the tool into forward motion.
- > The OK (cycle complete) or NOK (cycle not complete) will be rated by the following:-  
A tightening finished by a valid clutch or current shut off operation will be rated as OK.  
In the case of active auto reverse, the OK rating will only be given, if the initial tightening was OK and the tool reversed for the complete programmed reverse time. Failure to complete initial tightening, or not allowing the full reverse time to be completed, will result in a NOK condition.  
**WARNING:** A valid clutch or current shut off operation requires that the tool is held firmly against the fastener throughout the operation and for the tightening to be completed within the Final Time period. (If programmed).
- > All other operations will show a NOK display.

# ESP 6 - Option 3 and 4 Programming Description



**Desoutter Limited** Eaton Road Hemel Hempstead Hertfordshire HP2 7DR England

## Signals on the I/O connector:

Signal	I/O	Pin	Description	Signal Type	Signal Duration
EXTERNAL FORWARD	Input	21	Signal to run tool forward, can be used exclusive or together with the tool button.	L	24V signal Must be disabled and re enabled for the next cycle
EXTERNAL REVERSE	Input	22	Signal to run tool in reverse, can be used exclusive or together with the tool button.	L	24V signal Must be disabled and re enabled for the next cycle
EXTERNAL STOP	Input	12	Allows immediate stop of tool (depth sensor, park position)	P	24V signal. See Note below.
CYCLE COMPLETED (OK)	Output	2/15	Signals that the fastening is complete - i.e. clutch has fired or current shutoff has activated	L	24V signal Signal remains enabled until start of next tightening cycle (not reverse) or ESP is powered off
NOT COMPLETED (NOK)	Output	1/14	Signals that the tool has stopped, but fastening was not successful.	L	24V signal Signal remains enabled until start of next tightening cycle (not reverse) or ESP is powered off
PROG SEL 1	Input	23	Grp1:0V, Grp2:0V, Grp3:+24V, Grp4:+24V	L	24V signal level required to select required Program via Ext I/O
PROG SEL 2	Input	24	Grp1:0V, Grp2:+24V, Grp3:0V, Grp4:+24V	L	24V signal level required to select required Program via EXT I/O
+24V		5/18	24V from external power supply	L	Required for all External I/O operations
GND24V		6/7/13/ 19/20/ 25	0V return to external power supply	L	Required for all External I/O operations

**L** Signal level required for time period indicated.

**P** Can be a pulse with a minimum time duration of 200ms or signal level that should be disabled before start of next cycle. However if longer the external stop must be disabled before the start of the next cycle.

**Note:** An external 24V power supply is required to enable the external input and output signals.

Maximum output current per output is 500mA.  
Current per input is 9mA.

© Copyright 1999, Desoutter, HP2 7DR, UK.

All rights reserved. Any unauthorized use or copying of the contents or part thereof is prohibited. This applies in particular to trademarks, model denominations, part numbers and drawings.  
Use only authorized parts. Any damage or malfunction caused by the use of unauthorized parts is not covered by Warranty or Product Liability.