

Desoutter



Desoutter Limited. London NW9 6ND

HM55

- (GB)** Servicing Instructions
- (GB)** Operating Instructions
- (GB)** Parts List
- (D)** Wartungsanleitung
- (D)** Bedienungsanleitung
- (D)** Teileliste
- (F)** Manuel d'entretien
- (F)** Manuel d'utilisation
- (F)** Liste de pièces
- (E)** Instrucciones de Servicio
- (E)** Instrucciones de Operación
- (E)** Listas de Repuestos
- (E)** Instruções de Manutenção
- (P)** Instruções de Funcionamento
- (P)** Listas de Peças
- (I)** Istruzioni per la Manutenzione
- (I)** Istruzioni Operative
- (I)** Elenco delle Parti
- (I)** Οδηγίες Συντήρησης
- (GR)** Κατάλογοι Ανταλλακτικών Μερών
- (GR)** Οδηγίες Λειτουργίας
- (NL)** Onderhoudsinstructies
- (NL)** Bedieningsinstructies
- (NL)** Onderdelenlijst
- (DK)** Servicevejledning
- (DK)** Betjeningsvejledning
- (DK)** Liste over dele
- (N)** Serviceinstruksjoner
- (N)** Driftsinstruksjoner
- (N)** Delelister
- (N)** Serviceinstruksjoner
- (S)** Bruksanvisning
- (S)** Reservdelslista
- (S)** Huolto-ohjeet
- (FIN)** Osaluettelo
- (FIN)** Käyttöohjeet

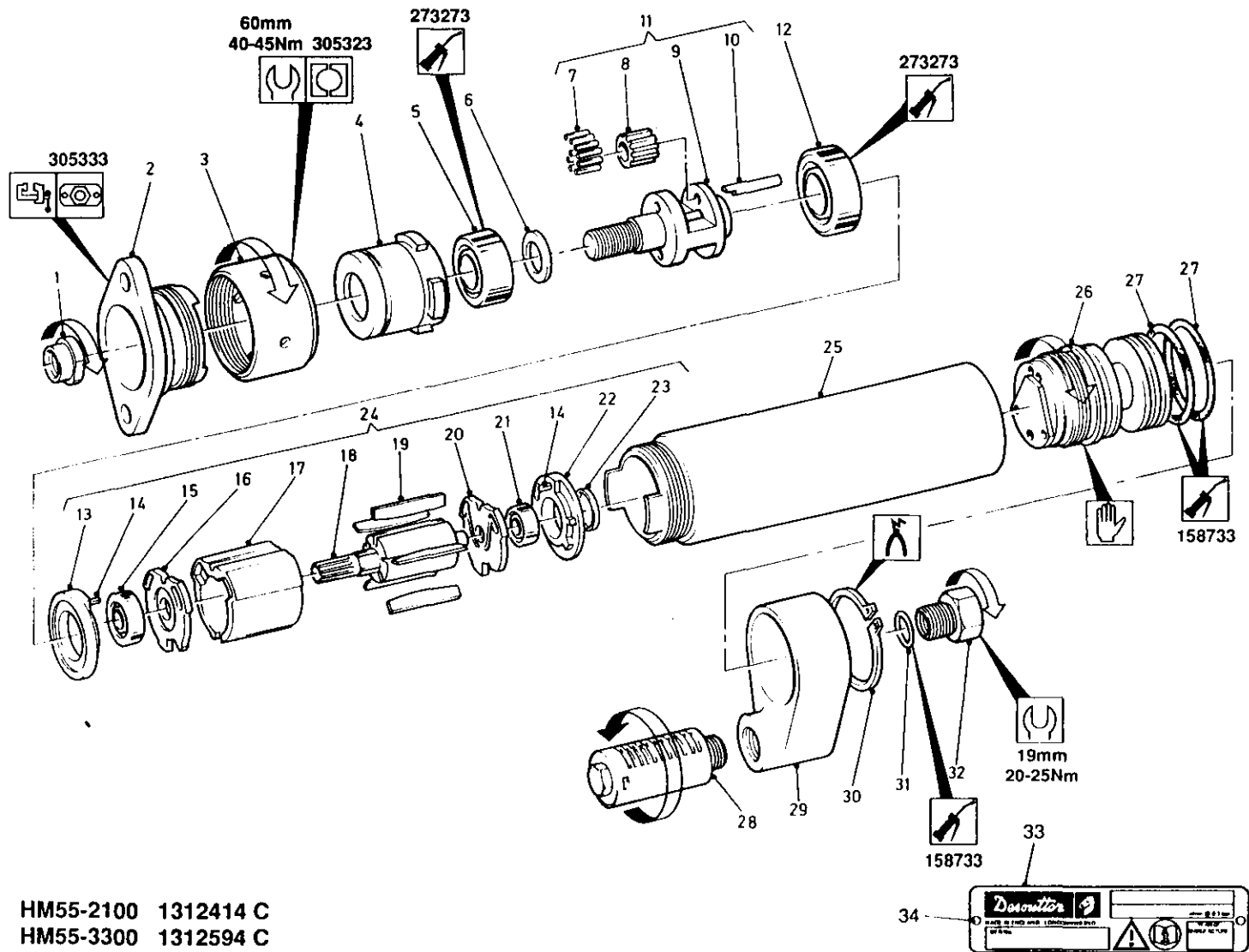

HM55-2100 1312414 C
HM55-3300 1312594 C

Parts List/Teileliste/Liste de Pièces



Desoutter Limited. London NW9 6ND

Item No. Pos.Nr.	Part No. Teil. No.	Qty Menge	Item No. Pos.Nr.	Part No. Teil. No.	Qty Menge
No. Article	Référence	Qté	No. Article	Référence	Qté
1	265593	1	* 15	80253	1
2	265543	1	* 16	265043	1
3	277663	1	17	265033	1
4	290153	1	18	265093	1
* 5	290633	1		HM-2100	
6	290853	1	-	290813	1
	HM-3300			HM-3300	
7	502103	2	19	9433	5
	HM-2100		20	265053	1
-	25963	20	21	500693	1
	HM-3300		22	265083	1
8	1353	2	23	256773	1
-	25263	2	24	290303	1
* 9	290463	1		HM-2100	
	HM-2100		-	290533	1
-	295613	1		HM-3300	
* 10	HM-3300		25	290553	1
	80013	2	26	290263	1
	HM-2100		27	166053	2
-	25963	2	28	208003	1
	HM-3300		29	290253	2
11	290513	1	30	158273	1
	HM-2100		31	268513	1
-	295633	1	32	42953 (BSP)	1
	HM-3300		-	47133 (NPT)	1
* 12	1673	1	33	355893	1
13	265063	1	34	54853	2
14	256113	2			

* Indicates normal replacement items. It is recommended that adequate stocks are held for servicing requirements.

Always quote tool model number, serial number and spare part number when ordering spares.

* Bedeutet normale Verschleißteile. Es empfiehlt sich eine angemessene Menge für Wartungszwecke auf Lager zu halten.

Bei der Bestellung von Ersatzteilen, bitte immer angeben: Typennummer der Bohrmaschine, Werknummer und Ersatzteilnummer.

* Le symbole astérisque (*) indique des articles de rechange normaux. Il est recommandé d'en conserver de stocks suffisants pour assurer toutes les opérations d'entretien courant.

Lors de la commande de pièces de rechange, toujours citer le numéro de modèle de l'outillage, son numéro de série et le numéro de référence de chaque pièce de rechange.

* Indica elementos de reposición regular. Se recomienda tener una cantidad adecuada de los mismos en reserva a efectos de mantenimiento.

Al encarga piezas de recambio, siempre debe indicarse el número de modelo de la herramienta, su número de serie y el número de la pieza de recambio.

* Indica itens que são substituídos regularmente. É recomendado que estoques adequados sejam mantidos para requisitos de manutenção.

Cite sempre o número do modelo da ferramenta, número de série, e número da peça acessória quando pedindo acessórios.

* L'asterisco denota ricambi normali. Si consiglia di mantenere scorte adeguate alle esigenze della manutenzione.

Nell'ordinazione di ricambi citari il numero di modello dell'utensile, il numero di matricola e quello di catalogo del pezzo.

* Σημαίνει συνθησιόμενα είδη (τεμάχια) για αντικατάσταση. Σας συνιστούμε να τηρείτε αρκετό απόθεμα από τα είδη που χρειάζονται αντικατάσταση.

Όταν παραγγέλνετε ανταλλακτικά πάντα να γράφετε τον αριθμό μοντέλου του εργαλείου, τον αριθμό σειράς και τον αριθμό ανταλλακτικού.

* Betekent normale reserveatikelen. Het verdient aanbeveling om voldoende voor onderhoudsbehoeften voordig te hebben.

Bij Bestelling van reserveonderdelen geef altijd modelnummer, volgnummer en reserveonderdeelnnummer van het werktuig op.

* Indikerer normale udskiftningsemner. Det anbefales at have rigelige forsyninger af dele til brug i forbindelse med eftersyn.

Opgiv altid det korrekte værktøjsmodelnummer, serienummer og reservedelsnummer ved bestilling af reservedele.

* Angir normale reservedeler. Det anbefales at tilstrekkelig antall reservedeler holdes på lager.

Ved bestilling av deler må man alltid oppgi verktøyets modellnr., serienr. og reservedelens nr.

* Utmärker normala reservdelar. Vi rekommenderar att tillräckligt antal lagras för serviceändamål.

Uppge alltid verktygets modellnummer, serienummer samt reservedelens nummer vid beställning av reservdelar.

* Viittaa tavallisiin varaosiin. Suosittelemme, että riittäviä määriä pidetään varastossa huoltotarpeita varten.

Työkalun mallinnumero, sarjanumero ja varaosan numero on aina mainttava tilattaessa.



Desoutter Limited. London NW9 6ND

STATEMENT OF USE

This motor is designed to be incorporated into a fixed or moving machine. It is for right hand rotation and should be mounted by the flange or threaded nose only. The risk of the motors being the source of ignition of a potentially explosive atmosphere is extremely small. The user is responsible for assessing the risks associated with the whole machine into which the motor is to be incorporated.

GENERAL

Recommended inlet hose

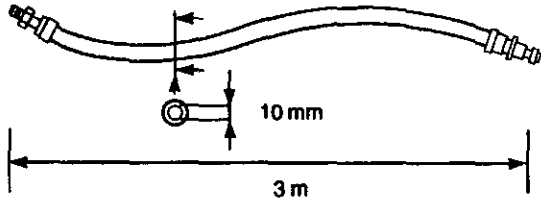

LUBRICATION

Correct lubrication is vital for the maximum performance of the tool and an airline lubricator should be fitted into the system down stream of the filter. Use ISO VG15.

158733 = Molykote PG 75	273283 = BP FG00EP
208893 = Rocal M204G	27662 (5L) = ISO VG15
273273 = BP Q5618	27652 (250ml) = ISO V15

DATA

Maximum air pressure Pmax	= 6.3 bar
Minimum air pressure Pmin	= 2 bar
Sound pressure level (dBA)	= 78 re.CAGI-PNEUROPT Test code
Vibration level (m/s ²)	= <2.5 re.ISO 8662

WEIGHT

Motor type/RPM	kg
HM55-2100	1.4
HM55-3300	1.4

ACCESSORIES

A range of accessories are available and suitable items should be selected from the Desoutter accessories catalogue.

MAINTENANCE INSTRUCTIONS

1. Servicing should be carried out at intervals of 1000 hours use.
2. All torque figures $\pm 10\%$.
3. Replace as necessary all 'O' rings, bearings and rotor blades, see service kits.
4.  Indicates direction of dismantling.
5. When disposing of components, lubricants, etc. ensure that the relevant safety procedures are carried out.

To Dismantle: Refer to main illustration

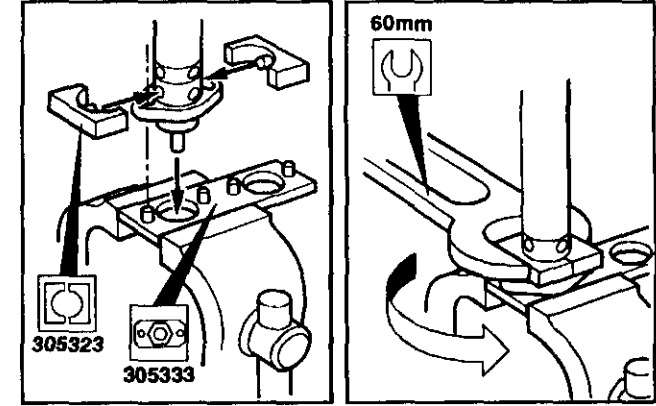

To Assemble: Motor complete, refer to main illustration

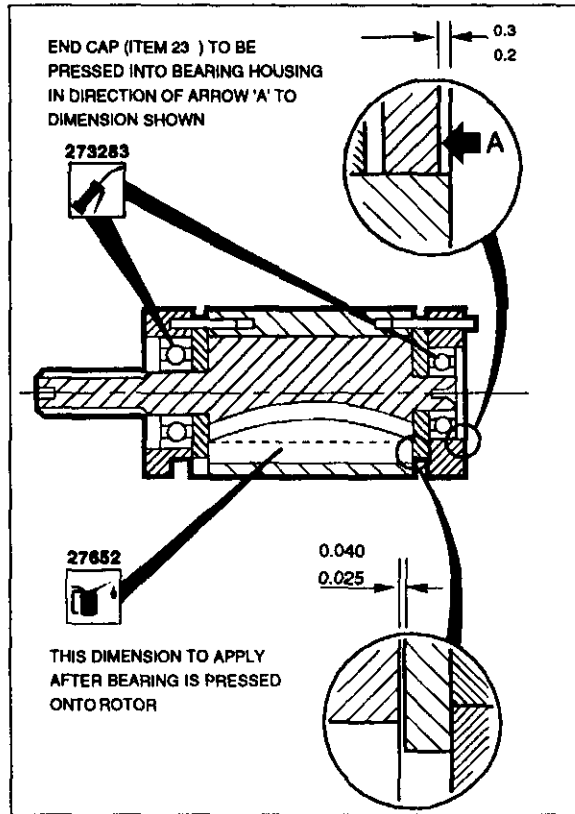
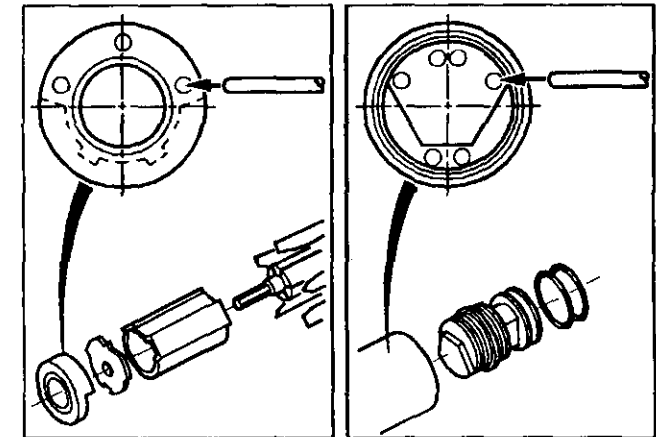

© Copyright 1994, Desoutter, London NW9 6ND, UK

Any unauthorized use or copying of the contents or part thereof is prohibited. This applies in particular to trademarks, model denominations, part numbers and drawings.

Use only authorized parts. Any damage or malfunction caused by the use of unauthorized parts is not covered by Warranty or Product Liability.