

# Desoutter



Desoutter Limited, HP2 7DR, UK

## S5V2A

(GB) Servicing Instructions  
Parts List  
Operating Instructions

(D) Wartungsanleitung  
Teilleiste  
Bedienungsanleitung

(F) Manuel d'entretien  
Liste de pièces  
Manuel d'utilisation

(E) Instrucciones de Servicio  
Listas de Repuestos  
Instrucciones de Operación

(P) Instruções de Manutenção  
Listas de Peças  
Instruções de Funcionamento

(I) Istruzioni per la Manutenzione  
Elenco delle Parti  
Istruzioni Operative

(GR) Οδηγίες Συντήρησης  
Κατάλογοι Ανταλλαχτιών  
Οδηγίες Λειτουργίας

(NL) Onderhoudsinstructies  
Onderdelenlijst  
Bedieningsinstructies

(DK) Servicevejledning  
Liste over dele  
Betjeningsvejledning

(N) Serviceinstruksjoner  
Deleliste  
Driftsinstruksjoner

(S) Serviceinstruktioner  
Reservdelista  
Bruksanvisning

(FIN) Huolto-ohjeet  
Osaluettelo  
Käyttöohjeet

	5/16"	ISO 1173 F6.3 (1/4")
S5V2A- 2000	1343044-F	1342994-F
S5V2A- 1100	1343204-F	1343124-F
S5V2A- 650	1343464-F	1343384-F
S5V2A- 400	1343624-F	1343544-F

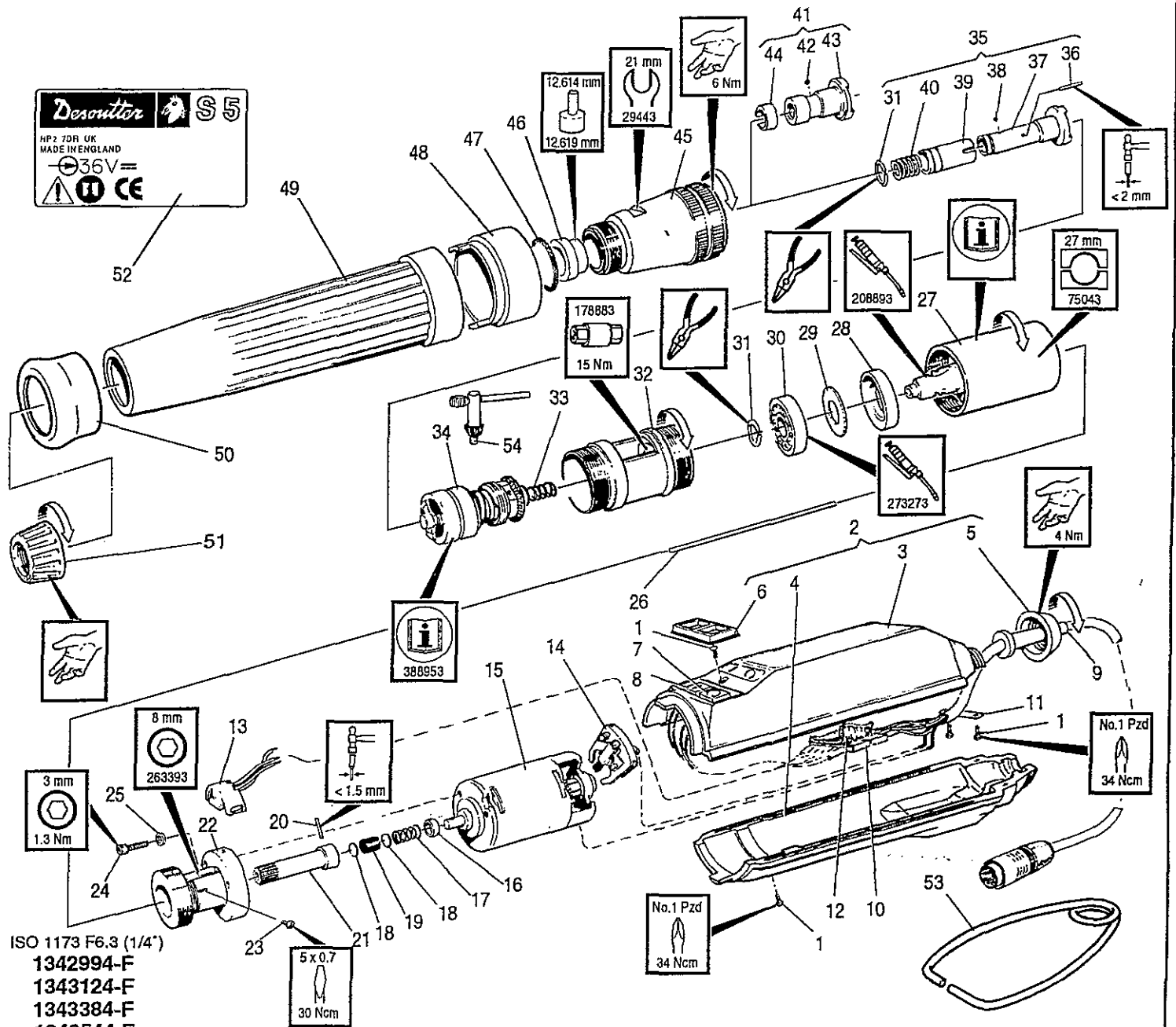

Item Ps. Nr. No. Article	Part No Teil Nr. Référence	Qty Menge Qté	Item Ps. Nr. No. Article	Part No Teil Nr. Référence	Qty Menge Qté
1	293373	4		(750RPM)	
2	278643	1		(450RPM)	
3	278663	1	35	370693	1
4	278673	1		(F6.3)	
5	259863	1	36	327143	1
6	292693	1	37	370663	1
7	292823	1	38	280313	2
8	292813	1	39	370673	1
9	457813	1	40	301013	1
10	259933	1	41	301143	1
11	260673	1		( $\frac{1}{16}$ "	
*12	262233	4	42	72408	1
13	291963	1	43	301153	1
14	310243	1	44	86058	1
15	298233	1	45	313113	1
16	259773	1	46	272863	2
17	259923	1	*47	239753	2
18	259783	2	48	259853	1
19	259913	1		(450RPM)	
*20	302243	2	49	304503	1
21	263693	1	50	411693	1
	(2000RPM)		51	177163	1
	263673	1	52	380863	1
	(1400RPM)		53	432663	1
	(450RPM)		54	29932	1
	275143	1			
	(750RPM)				
22	289813	1			
23	281363	2			
24	236233	3			
25	291923	3			
26	276993	1			
	(2000RPM)				
	(1400RPM)				
	(750RPM)				
	291313	1			
	(450RPM)				
27	3 of 15	1			
28	216483	1			
29	206633	1			
*30	178543	1			
*31	200083	2			
32	302763	1			
33	252563	1			
34	301323	1			
	(White)				
	(2000RPM)				
	(1400RPM)				
	301293	1			
	(Black)				

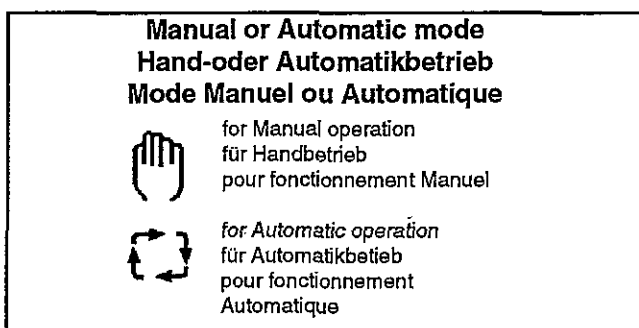
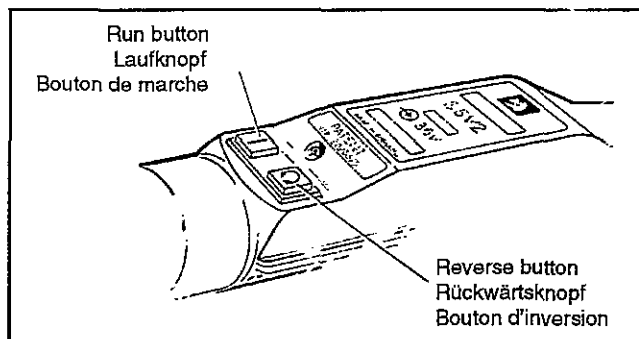
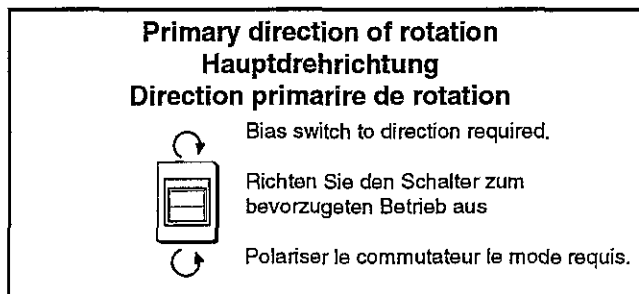

- GB** \* Indicates normal replacement items. It is recommended that adequate stocks are held for servicing requirements. Always quote tool model number, serial number and spare part number when ordering spares.
- D** \* Bedeutet normale Verschleißteile. Es empfiehlt sich eine angemessene Menge für Wartungszwecke auf Lager zu halten. Bei der Bestellung von Ersatzteilen, bitte immer angeben: Typennummer der Bohrmaschine, Werknummer und Ersatzteilnummer.
- F** \* Le symbole astérisque (\*) indique des articles de rechange normaux. Il est recommandé d'en conserver des stocks suffisants pour assurer toutes les opérations d'entretien courant. Lors de la commande de pièces de rechange, toujours citer le numéro de modèle de l'outilage, son numéro de série et le numéro de référence de chaque pièce de rechange.
- E** \* Indica elementos de reposición regular. Se recomienda tener una cantidad adecuada de los mismos en reserva a efectos de mantenimiento. Al encargar piezas de recambio, siempre debe indicarse el número de modelo de la herramienta, su número de serie y el número de la pieza de recambio.
- P** \* Indica itens que são substituídos regularmente. É recomendado que estoques adequados sejam mantidos para requisitos de manutenção. Cite sempre o número do modelo da ferramenta, número de série, e número da peça acessória quando pedindo acessórios.
- I** \* L'asterisco denota ricambi normali. Si consiglia di mantenere scorte adeguate alle esigenze della manutenzione. Nell'ordinazione di ricambi citare il numero di modello dell'utensile, il numero di matricola e quello di catalogo del pezzo.
- GR** Σημαίνει συνηθισμένα είδη (τεμάχια) για αντικατάσταση. Σας συνιστούμε τηρείτε αρκετό απόθεμα από τα είδη που χρειάζονται αντικατάσταση. Όταν παραγγέλνετε ανταλλακτικά πάντα να γράφετε τον αριθμό εντέλου του εργαλείου, τον αριθμό σειράς και τον αριθμό ανταλλακτικού.
- NL** \* Betekent normale reserveartikelen. Het verdient aanbeveling om voldoende voor onderhoudsbehoeften voorradig te hebben. Bij bestelling van reserveonderdelen geef altijd modelnummer, volgnummer en reserveonderdeelnnummer van het werktuig op.
- DK** \* Indikerer normale udskiftningsemner. Det anbefales at have rigelige forsyninger af dele til brug i forbindelse med eftersyn. Opgiv altid det korrekte værktøjsmodelnummer, serienummer og reservedelsnummer ved bestilling af reservedele.
- N** \* Angir normale reservedeler. Det anbefales at tilstrekkelig antal reservedeler holdes på lager. Ved bestilling av deler må man alltid oppgi verktøyetts modellnr., serienr. og reservedelens nr.
- S** \* Utmärker normala reservdelar. Vi rekommenderar att tillräckligt antal lagras för serviceändamål. Uppge alltid verktygets modellnummer, serienummer samt reservdelens nummer vid beställning av reservdelar.
- FIN** \* Viittaa tavallisiin varaosiin. Suosittelemme, että riittävät määrät pidetään varastossa huoltotarpeita varten. Työkalun mallinnumero, sarjanumero ja varaosan numero on aina mainittava tilattaessa.

# S5V2A – Gearbox Parts List / Getriebe Teileliste / Boîte de Vitesse Liste de Pièces

Item Ps. Nr. No. Article	Part No Teil Nr. Référence	Qty Menge Qté	Item Ps. Nr. No. Article	Part No Teil Nr. Référence	Qty Menge Qté
1	259843 (2000RPM)	1	12	170243 (1400RPM)	1
	(1400RPM)	1		(750RPM)	1
	(750RPM)	1		(450RPM)	2
	260663 (450RPM)	1	13	174313 (1400RPM)	1
2	205183	1		174243 (750RPM)	1
3	224513 (2000RPM)	1		174313 (450RPM)	2
	205193 (1400RPM)	1	14	274433 (750RPM)	3
	(750RPM)	1		200213 (450RPM)	1
	(450RPM)	1	15	200213 (450RPM)	1
4	170233 (2000RPM)	3	16	174303 (1400RPM)	1
	(1400RPM)	6		(750RPM)	1
	(750RPM)	6		(450RPM)	1
	(450RPM)	9		174253 (750RPM)	1
5	224503 (2000RPM)	3			
	170223 (1400RPM)	6			
	(750RPM)	3			
	(450RPM)	9			
6	224533 (2000RPM)	1			
	170273 (1400RPM)	1			
	(750RPM)	1			
	(450RPM)	2			
7	177173	1			
8	259823 (2000RPM)	1			
9	170213 (1400RPM)	2			
	(750RPM)	1			
	(450RPM)	3			
10	170253 (1400RPM)	1			
	(750RPM)	1			
	(450RPM)	2			
*11	2423 (1400RPM)	1			
	(750RPM)	1			
	(450RPM)	2			

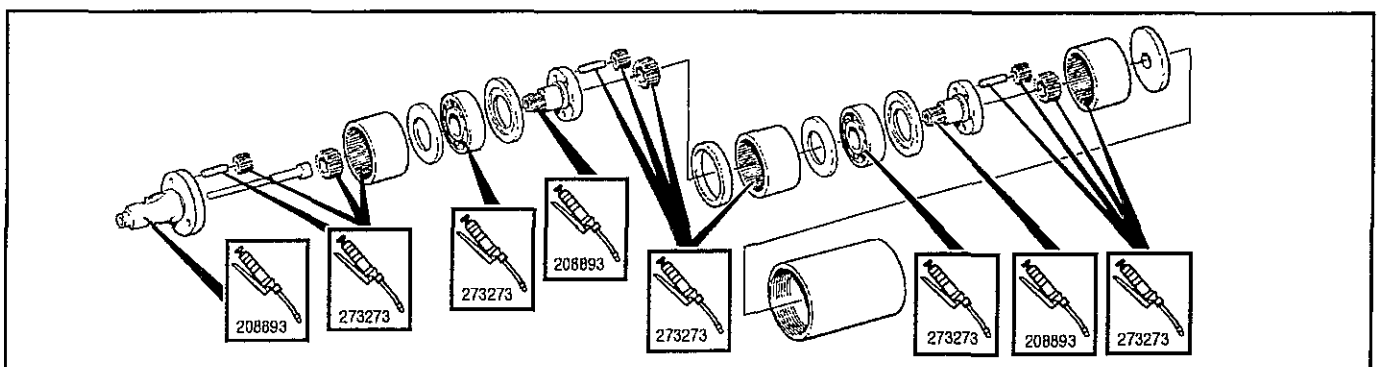
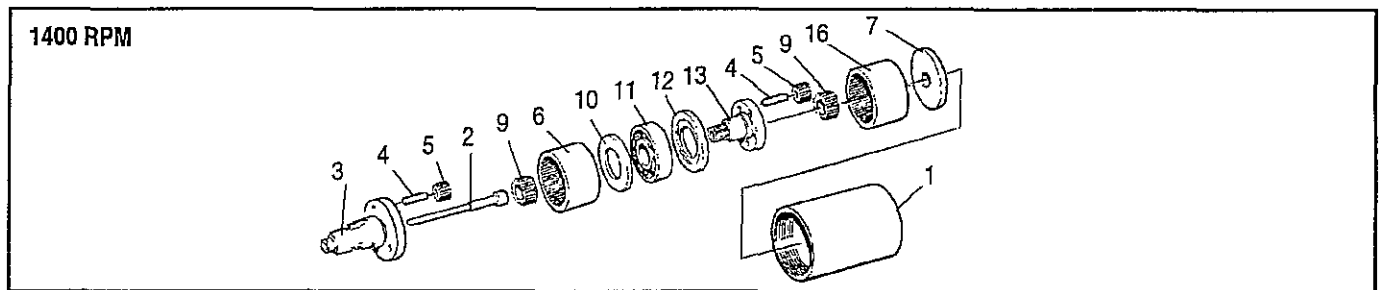
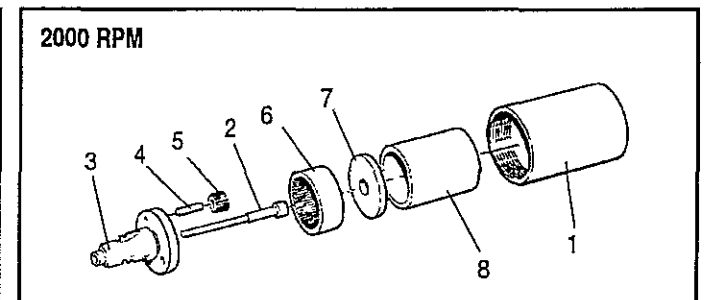
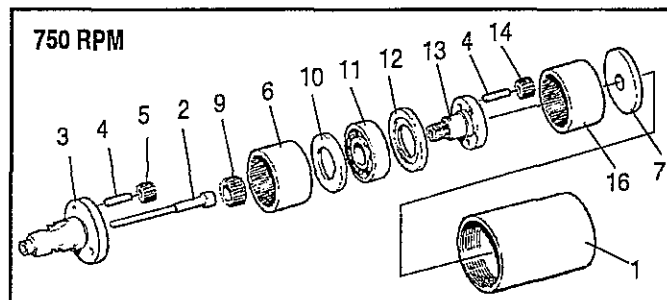
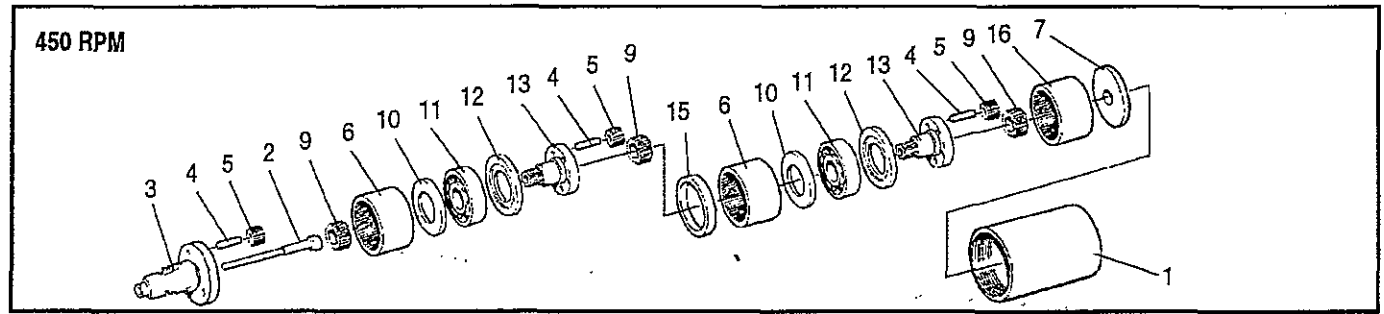

**STATEMENT OF USE**

Product is designed for installing and removing threaded fasteners in wood, metal and plastic.

**REQUIREMENTS**

This tool requires a 36V DC supply and is to be operated through a controller on a 42V DC supply.

Units available are listed below:

ESP1 Power module requires mains voltage supply, provides a single 42V DC output.

ESP2 Power module requires mains voltage supply, provides five 42V DC outputs.

ESP3 Controller unit provides three running options.



ESP4 Controller unit provides several running options and a 9 position speed selector switch.

ESP5 Combined power and controller module requires mains voltage supply, provides one running option.

Where controllers have manual or automatic mode options, this tool may be used in either mode.

**ACCESSORIES**

A wide range of accessories are available and suitable items should be selected from the relevant Desoutter catalogue.

	 <b>WARNING</b>
BEFORE USING, INSTALLING, REPAIRING OR CHANGING ACCESSORIES, READ AND UNDERSTAND THESE INSTRUCTIONS.	
<ol style="list-style-type: none"> <li>1. Tool operates through a 36V DC supply - do not connect directly to the mains.</li> <li>2. Disconnect the power supply before handling the screwdriver bit or socket or dismantling the tool.</li> <li>3. Keep loose articles of clothing or long hair away from the tool when in use.</li> <li>4. Hold the tool correctly; be ready to counteract normal or sudden movements - have both hands available.</li> <li>5. Do not use in confined spaces; beware of crushing hands between the tool and workpiece, especially when unscrewing.</li> <li>6. Immediately after adjusting the clutch, check for correct operation.</li> <li>7. Do not use in worn condition; the clutch may not operate, resulting in sudden rotation of the tool handle.</li> <li>8. Ensure that the workpiece is properly supported.</li> <li>9. Must not be used in explosive atmospheres.</li> <li>10. Power tools are not insulated from coming into contact with electric power.</li> </ol>	

**OPERATING INSTRUCTIONS**

With the correct accessory fitted, connect the tool through the controller to the power supply.

Select the appropriate programme on the controller from the normal/slow start, auto reverse and timed reverse options.

Grip the tool around the motor case and press the tool into the fixing that is to be tightened; the motor will start when the controller is in Automatic mode.

When in manual mode the motor will not start until the RUN button is pressed.

The fixing is tightened to the required torque set by adjusting the tension on the clutch spring.

The clutch resets when the tool is lifted from the tightened fastener. To engage reverse rotation press the reverse button and hold the tool against the fastener.

NOTE: In tools with standard clutches, the torque control does not operate in reverse, the torque output in reverse equals motor stall torque.

Do not allow tool to stall for more than one second.

Default push start rotation is clockwise; this may be changed by pressing both run and reverse buttons together for five seconds, then releasing both together, followed by pressing either the run button (clockwise) or the reverse button (anti-clockwise).

**MAINTENANCE INSTRUCTIONS****Lubrication**

157833 = Molykote Plastislip PG75

273273 = BP Q5618

208893 = Rocol M204G

Do not pack gears or bearings with grease, only lightly coat.

Use only the minimum amount of grease to locate components when assembling.

**Assembly and Dismantling**

Follow normal engineering practices and with references to the illustration build the components into sub-assemblies.

Disconnect Connector (10). Desolder only those wires necessary to component removal.

The NORTH POLE (white paint) of magnet (19) MUST be assembled into the transmission shaft (21) FIRST.

**To Set the Hall Effect**

Remove case halves (5,6) and screws (18),

Place the Hall Effect Carrier assembly as fully forward as adjustment will allow and retain with screws (23) very lightly.

Ensure motor GREY wire is connected to '+' motor terminal.

Connect to controller; set for automatic operation; switch on mains supply; the motor should RUN.

Move the Hall Effect Carrier assembly towards the motor, noting when the motor switches OFF.

From this point move the Hall Effect Carrier assembly FORWARD ONE INCREMENT 0.5-1.0mm.

NOTE: The Hall Effect Carrier adjustment is in increments of 0.5mm.

Switch off power supply, tighten screws (23) and replace case halves.

**DATA**

Rated Input = 35 W  
 Rated Current = 2.5 amps.  
 Sound Pressure Level (dBA) = 59 ± 2 re. CAGI-PNEUROP Test code

Vibration Level (m/sec<sup>2</sup>) = < 2.5 re. ISO 8662



**Weight**

S5V2A-2000,1400,750 = 0.8 kg

S5V2A- 450 = 0.9 kg

**TORQUE RANGE****Clutch Spring**

COLOUR	PART No.	TOOL SPEED	TORQUE RANGE Nm
Black	179923	2000 & 1400	0.4 - 0.82
Black	179923	750	0.63 - 0.82
Black	179923	450	0.7 - 0.82
White	179133	2000	0.63 - 0.9
White	179133	1400	0.63 - 0.8
White	179133	750	0.63 - 1.5
White	179133	450	0.7 - 2.3

Part No.	 <b>WARNING</b>	 
278663	= PA 6/6, 30%gf, <0.1%Cd	
278673		
292693		

©Copyright 1997, Desoutter, HP2 7DR, UK

All rights reserved. Any unauthorized use or copying of the contents or part thereof is prohibited. This applies in particular to trademarks, model denominations, part numbers and drawings.

Use only authorized parts. Any damage or malfunction caused by the use of unauthorized parts is not covered by Warranty or Product Liability.

**Desoutter** 

Desoutter Limited. HP2 7DR, UK