

# **DTI** 8000

DESIGN TOOL INC.

## **AUTOMATIC NAIL GLIDE GUN**

• **FAST** • **EFFICIENT** • **ACCURATE** • **AFFORDABLE**



*Fast,  
Modern Way*

**MODEL #8000-001 AUTOMATIC FEED  
NAIL GLIDE GUN**

*Slow, Old Fashioned Way*



**LOUZAMPINI  
& ASSOCIATES**

# DTI 8000 AUTOMATIC FEED NAIL GLIDE GUN

DESIGN TOOL INC.

## SPECIAL FEATURES:

- Light-weight, reduces operator fatigue
- Unique barrel design will drive nail straight every time
- Adjustable driving power for varying hardness of frame material
- Machine will not waste nail glides
- Operator may drive up to 60 nail glides per minute
- Speeds production—one operator may do the work of four
- Minimum maintenance

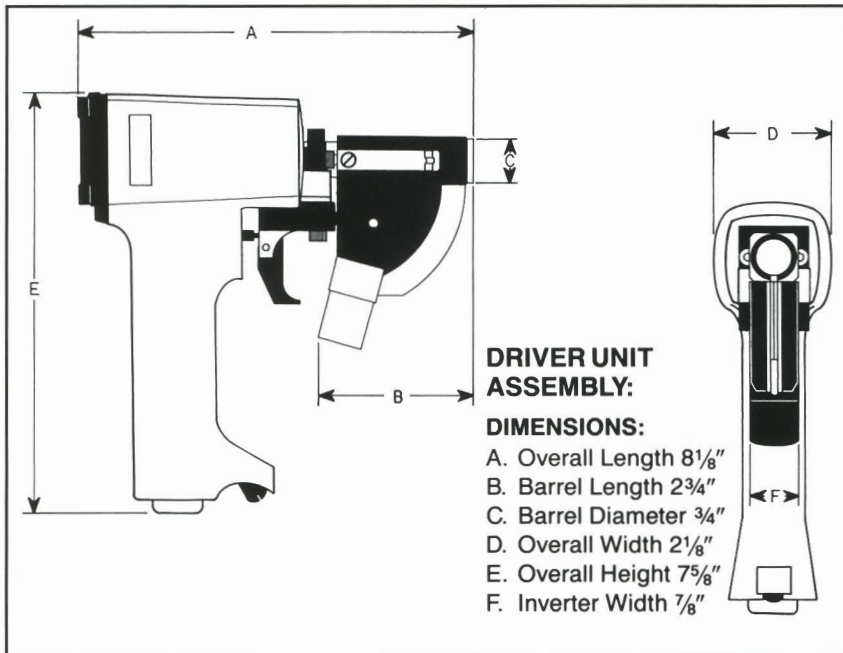

## SPECIFICATIONS:

### APPLICATION:

- Attaching nail glides to bottom of furniture

### FASTENERS:

- Standard nail glides

### BASE UNIT ASSEMBLY:

- Weight approx. 85 lbs.
- Width 14 inches
- Length 20 inches
- Height 8<sup>3</sup>/<sub>4</sub> inches

### FEEDER BOWL:

- Diameter 12 inches
- Capacity approx. 2000 glides

### DRIVER UNIT ASSEMBLY:

- Weight approx. 3<sup>3</sup>/<sub>4</sub> lbs.
- Modified Bostitch driver model T29

### ELECTRICAL SUPPLY:

- 110 volts (electricity only required to operate feeder bowl)

### AIR SUPPLY:

- Air pressure 45 to 55 PSI (determined by hardness of material)
- Air filtration—50 micron
- Hose size—1/4" I.D.

Our Area Code Has Changed To



Distributed by

**LOUZAMPINI & ASSOCIATES**

[www.PneumaticToolsOnline.com](http://www.PneumaticToolsOnline.com)

For More Info or to place an order call us:

**1-800-353-4676**

(401-354-8878 international)